



*Depump* **SLURRY PUMPS  
BRUCHURE**

DEPUMP TECHNOLOGY SHIJIAZHUANG CO.,LTD

# MAH SLURRY PUMPS

---





# MAH HORIZONTAL SLURRY PUMPS

**Heavy duty, horizontal slurry pumps.** High efficiency transfer of abraive and high density slurries with extended wear life and reliable service intervals.

## VERSATILE HEAVY DUTY SOLUTION

MAH series pumps are heavy duty horizontal slurry pumps designed to handle the transfer of abraive and high density slurries in mining and heavy industry.

MAH pumps feature a rugged cast iron construction with replaceable wear liners available in 27% chrome white iron, rubber or urethane to suit a wide range of applications, slurry types and consistencies.

Pumps are available in sizes ranging from 1 inch (25mm) to 18 inch (450mm) discharge and feature high efficiency performance capable of flow rates from 10.8 to 6500 m<sup>3</sup>/hour (48-28600USGPM) and heads up to 125 metres (410ft) for high head models.

All depon MAH slurry pumps are designed to be interchangeable with the most common slurry pump footprints used by the mining industry.

MAH pumps are manufactured using the highest quality materials to ensure reliability and extended service life in heavy duty applications.

MAH pumps are manufactured with a rugged cast iron outer casing which features reinforcing ribs for excellent high pressure strength and safety.

## WEAR LINERS

A range of replaceable wear liners are available in 27% chrome white iron, rubber or urethane to suit the requirements of specific applications and slurry types. Wear liners are easily replaced when required by simply removing the front cover plate bolts and sliding off the front cover. This allows minimal downtime and simple servicing for maintenance staff.

## IMPELLERS

The impeller features pumpout vanes on the rear face to prevent recirculation. Impellers are available in 27% chrome white iron or rubber to suit the requirements of the pumped product and are easily accessible by simply removing the front cover plate bolts and sliding off the front cover.

## EXTERNAL IMPELLER ADJUSTMENT

An external impeller adjustment bolt is located under the bearing assembly and is easily accessible. This allows for changes to be made to the impeller clearance to maximise efficiency and service life without removing the front cover plate or disconnecting pipework or the bearing assembly. The system allows quick and simple adjustments to be made to compensate for wear and changes in operating conditions and duty points.

**DEPON MAH 2x1.5B  
HORIZONTAL SLURRY PUMP**



**DEPON 4x3EHH**





MAH pumps are fitted with heavy duty bearing assemblies with angular contact bearings in the wet end and single or double row deep groove roller bearings in the drive end. Bearings are grease lubricated as standard and are available with the option of oil lubrication to meet customer requirements. Bearing assemblies are fitted to the bearing frame with four through bolts allowing for quick removal and simple servicing.

#### **SHAFT SEALING OPTIONS**

Pumps are fitted with packed gland type shaft seals as standard with PTFE packing and pumped product lubrication. Optional external clean water lubrication is available as an option to suit applications where product lubrication is not viable.

#### **MECHANICAL SEAL**

A range of mechanical seals are available to replace the packed gland shaft seal. Adaptor plates can be easily fitted to match the requirements of specific types of mechanical seals and seals are available in a wide range of materials.

#### **EXPELLER**

MAH pumps are fitted with an expeller as standard which reduces seal face pressure and reduces recirculation to extend seal life and reduce impeller wear.

#### **100% INTERCHANGEABLE**

All MAH spare parts are fully interchangeable with the most common slurry pump design in the mining industry. High quality Milestone spare parts can be fitted into existing pumps to improve performance and extend service life.

depon MAH  
Horizontal Slurry  
Pumps are 100% fully  
interchangeable with  
the most common  
slurry pump design in  
the mining industry.

# PUMP PERFORMANCE

## RUBBER LINED PUMPS

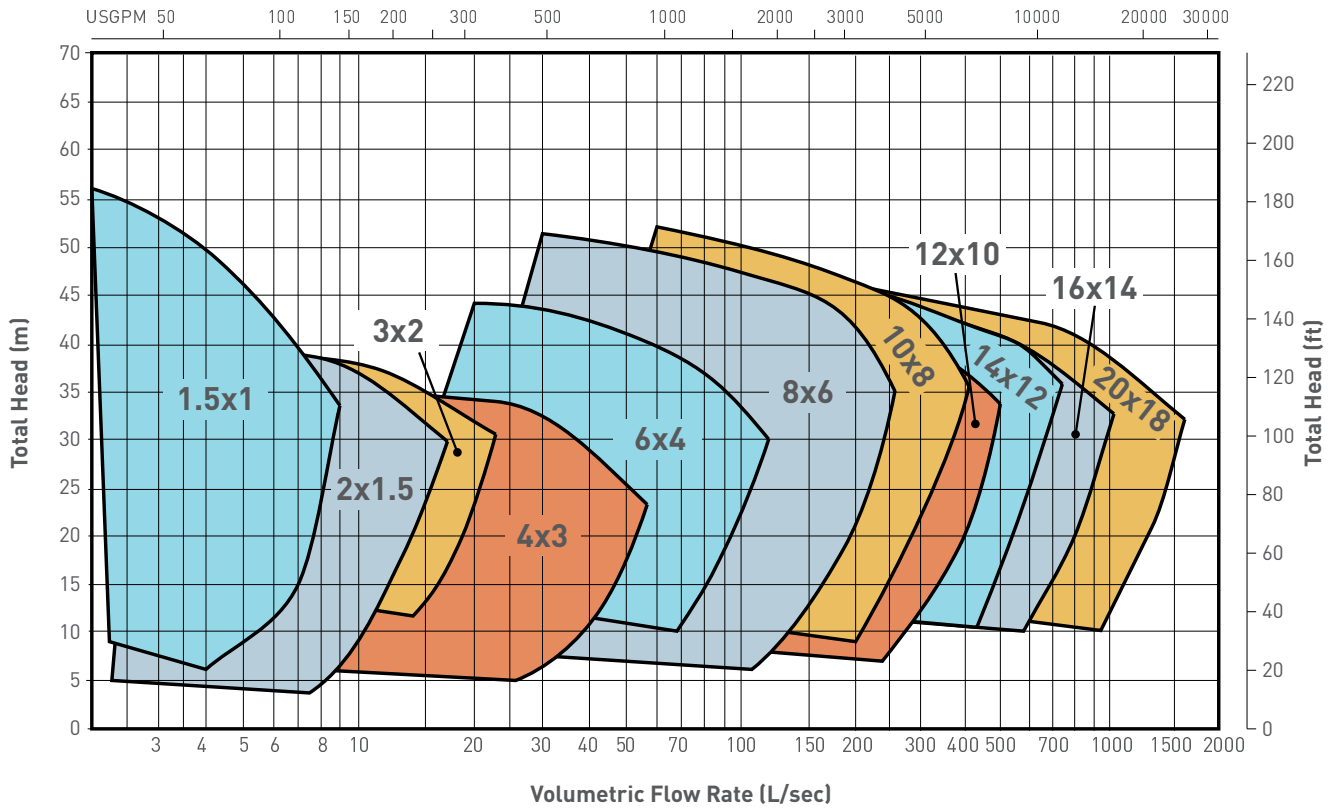

# METAL LINED PUMPS

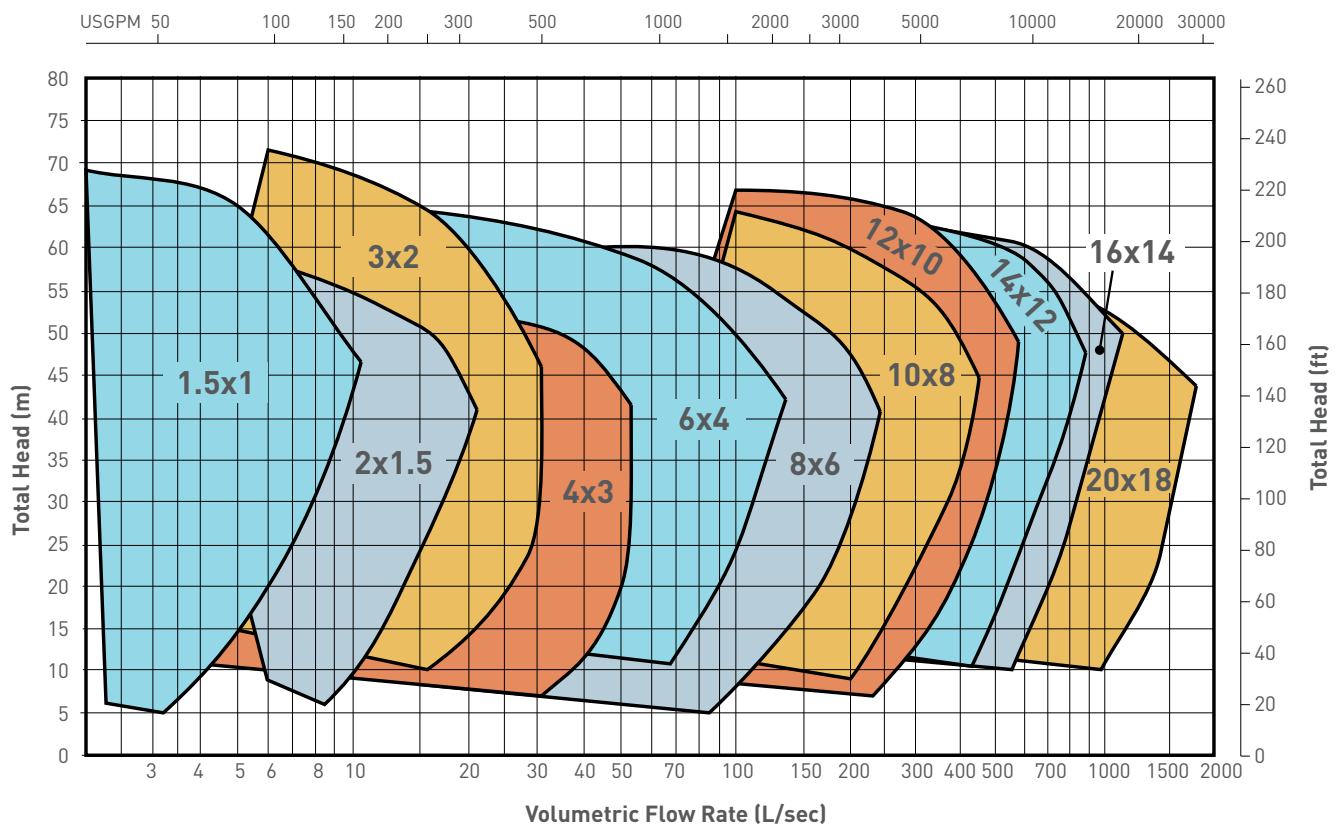

Performance curves are for clean, cold water only. Contact us to discuss pump selections for specific applications.

# HIGH HEAD PUMPS

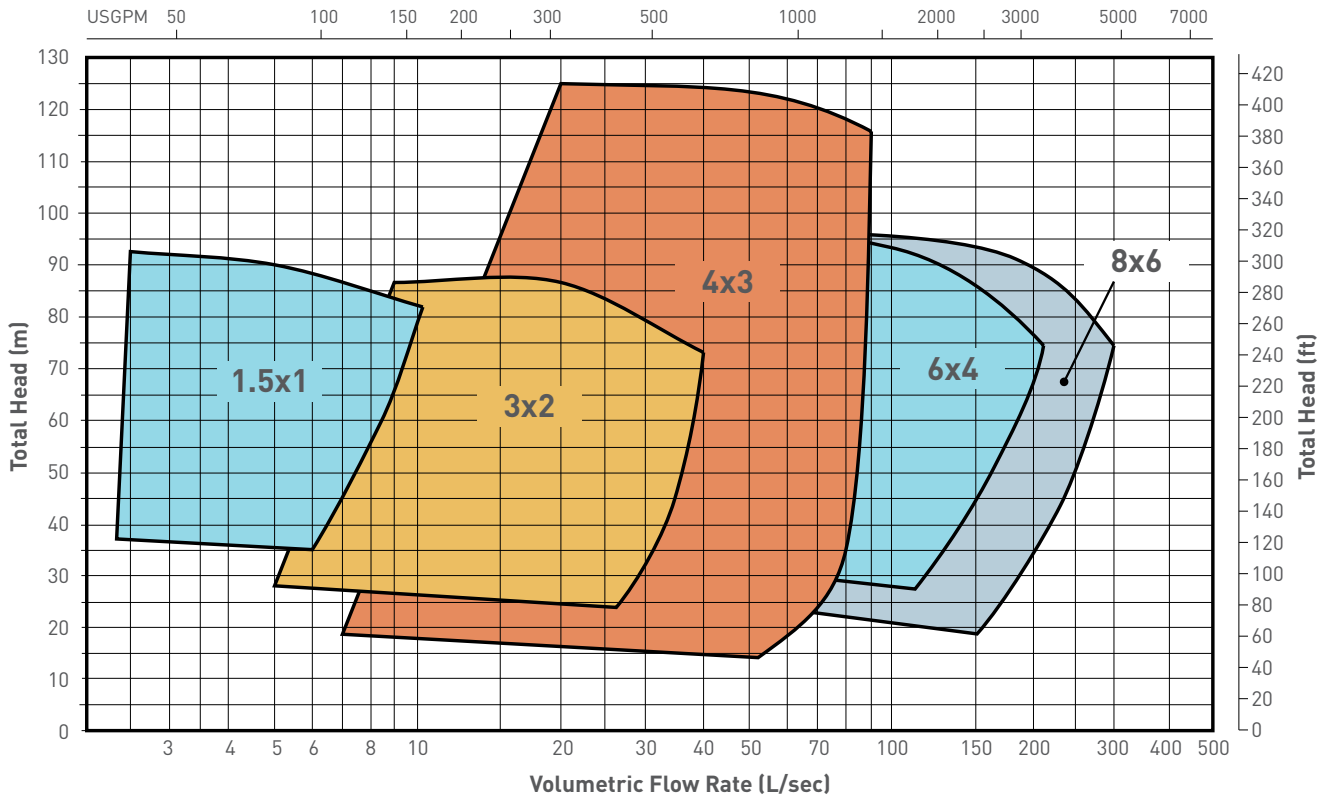

**DEPON 6x4FHH  
HIGH HEAD SLURRY PUMP.**

# MAH 1.5x1

## METAL LINER AND IMPELLER

### PUMP SPECIFICATIONS

Outlet/ Inlet (mm)	Bearing Frame	Max Power (kW)	Max Particle Size (mm)	Impeller	No. of Vanes	Impeller Material	Impeller/ Vane Dia. (mm)	Wear Liner Material
32/25	B	15	14	B1127	5	27% Chrome White Iron	159/152	27% Chrome White Iron

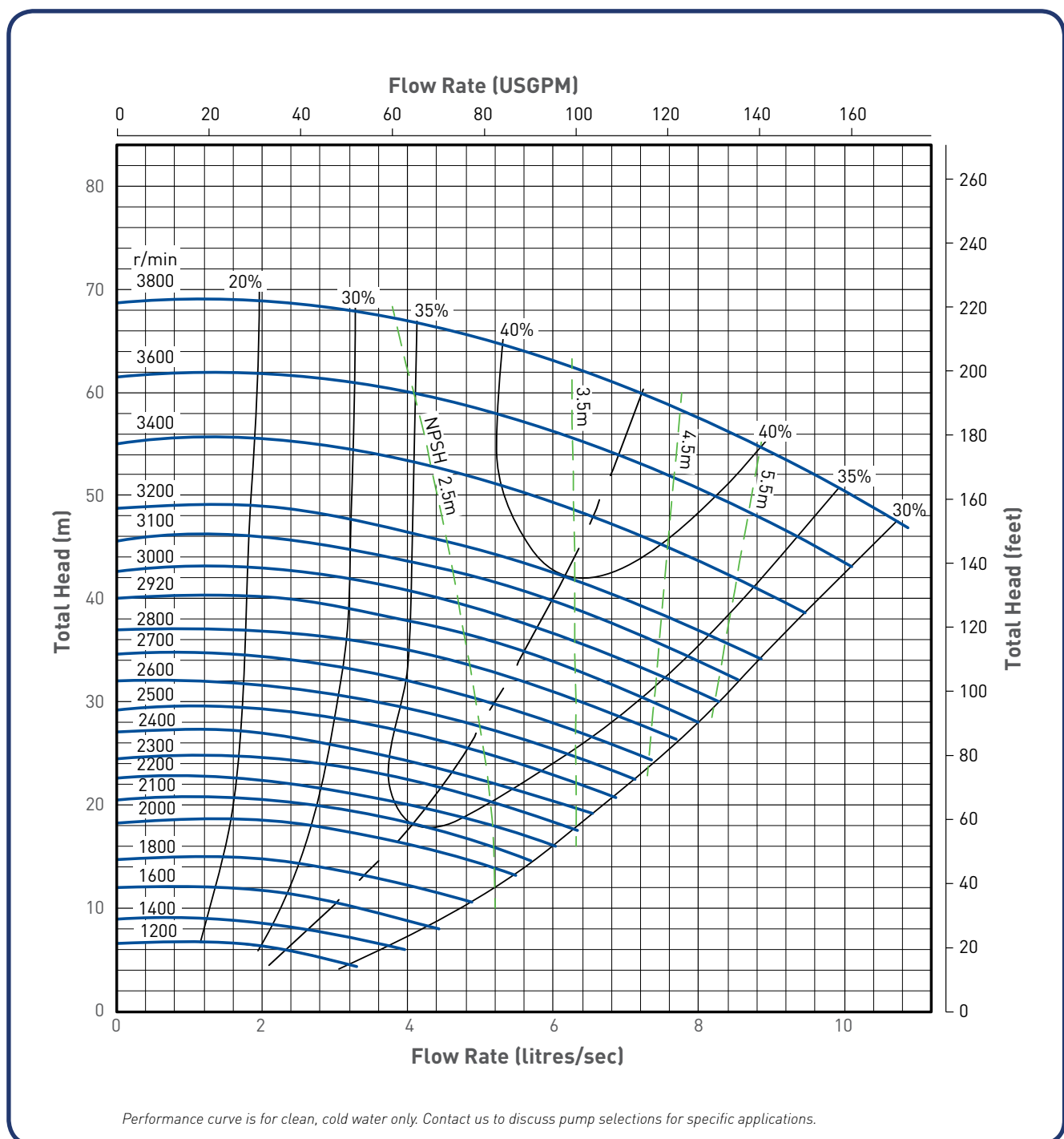

# MAH 1.5x1

## RUBBER LINER AND IMPELLER

### PUMP SPECIFICATIONS

Outlet/ Inlet (mm)	Bearing Frame	Max Power (kW)	Max Particle Size (mm)	Impeller	No. of Vanes	Impeller Material	Impeller/ Vane Dia. (mm)	Wear Liner Material
32/25	B	15	20	B1052	5	Rubber Lined High Tensile Steel	159/152	Rubber

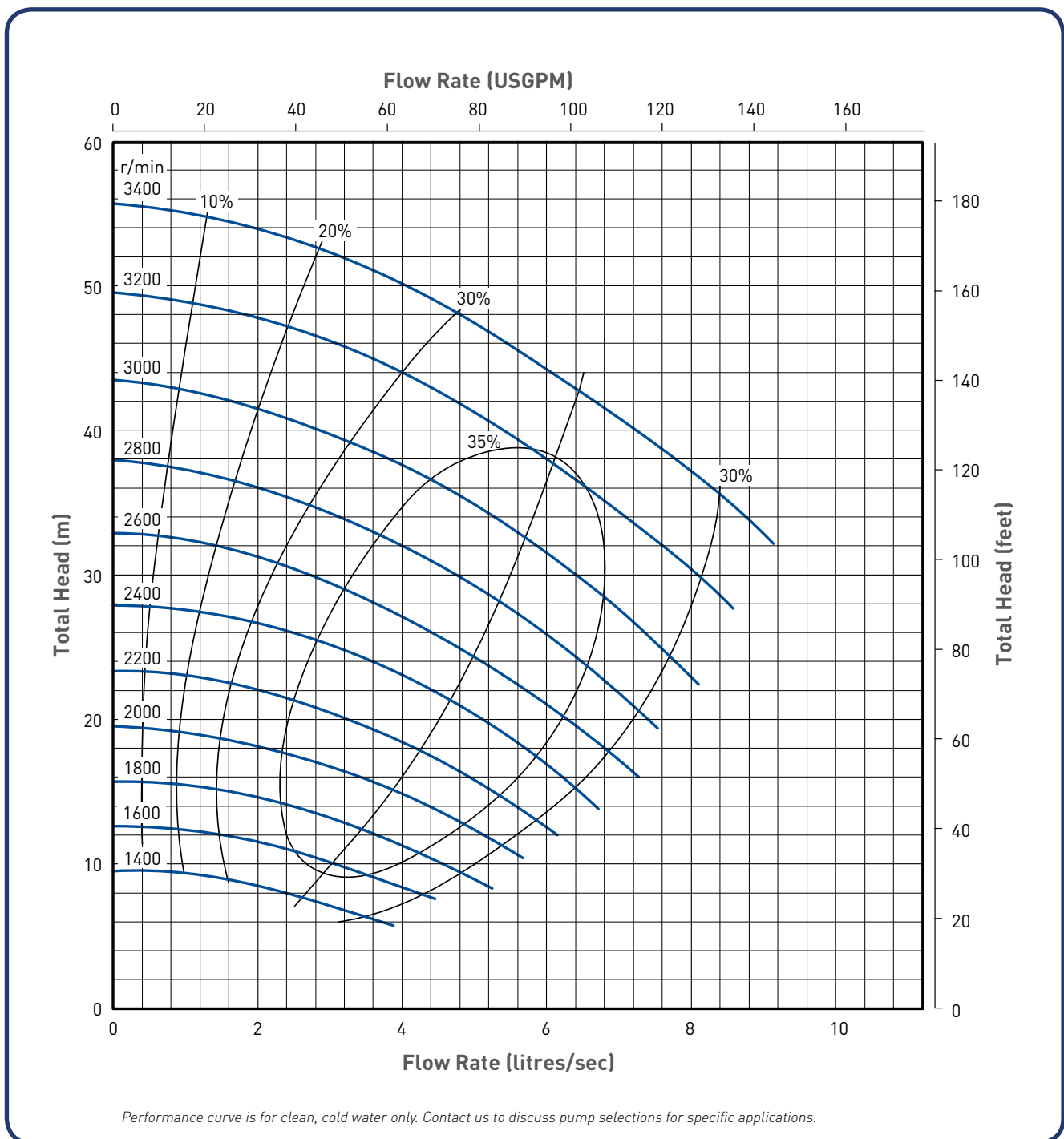

# MHH 1.5x1

## HIGH HEAD SLURRY PUMP

### PUMP SPECIFICATIONS

Outlet/ Inlet (mm)	Bearing Frame	Max Power (kW)	Max Particle Size (mm)	Impeller	No. of Vanes	Impeller Material	Impeller/ Vane Dia. (mm)	Wear Liner Material
32/25	C	30	16	MCH1127	5	27% Chrome White Iron	343/330	27% Chrome White Iron

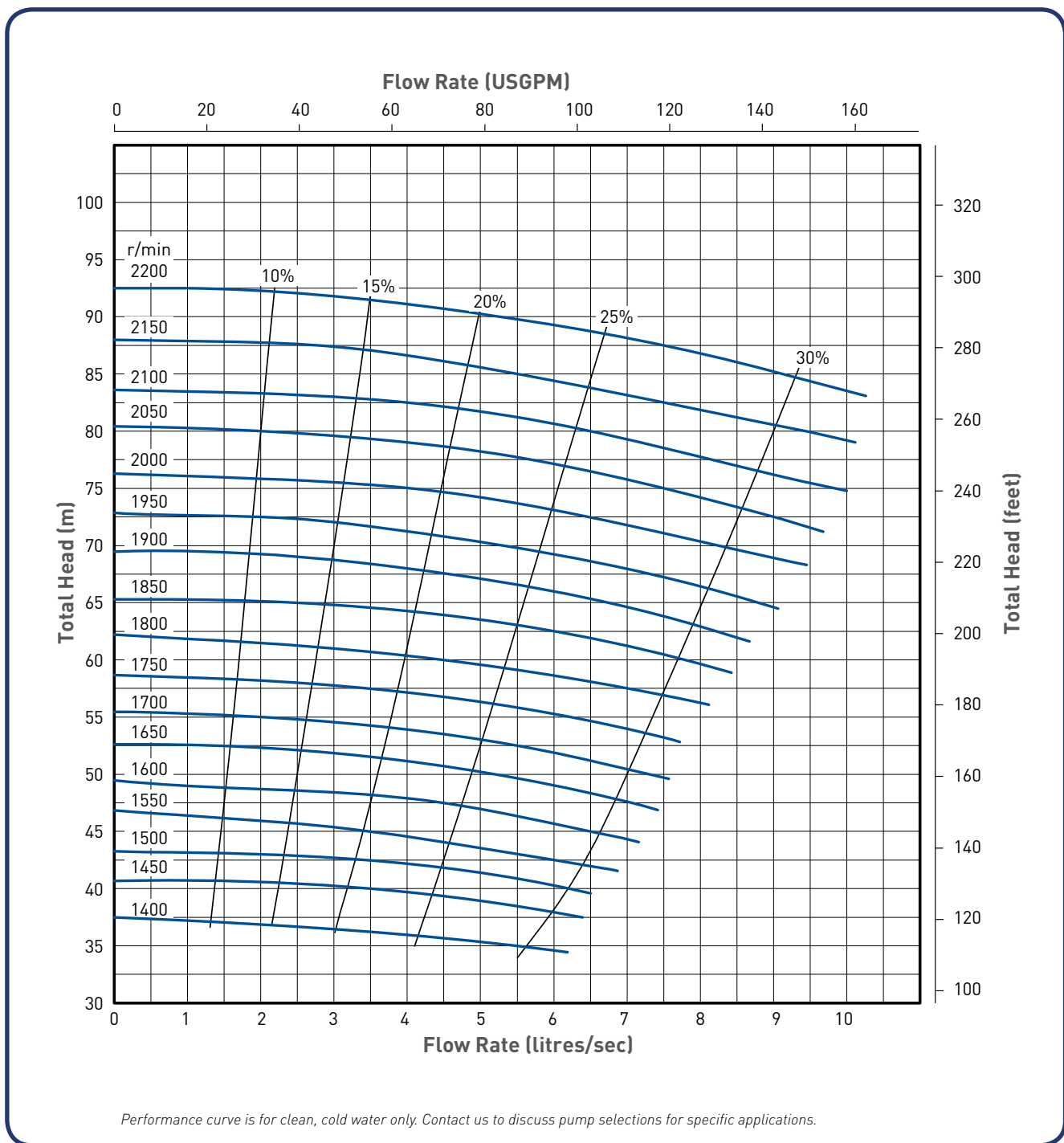

# MAH 2x1.5

## METAL LINER AND IMPELLER

### PUMP SPECIFICATIONS

Outlet/ Inlet (mm)	Bearing Frame	Max Power (kW)	Max Particle Size (mm)	Impeller	No. of Vanes	Impeller Material	Impeller/ Vane Dia. (mm)	Wear Liner Material
50/32	B	15	19	B15127	5	27% Chrome White Iron	184	27% Chrome White Iron

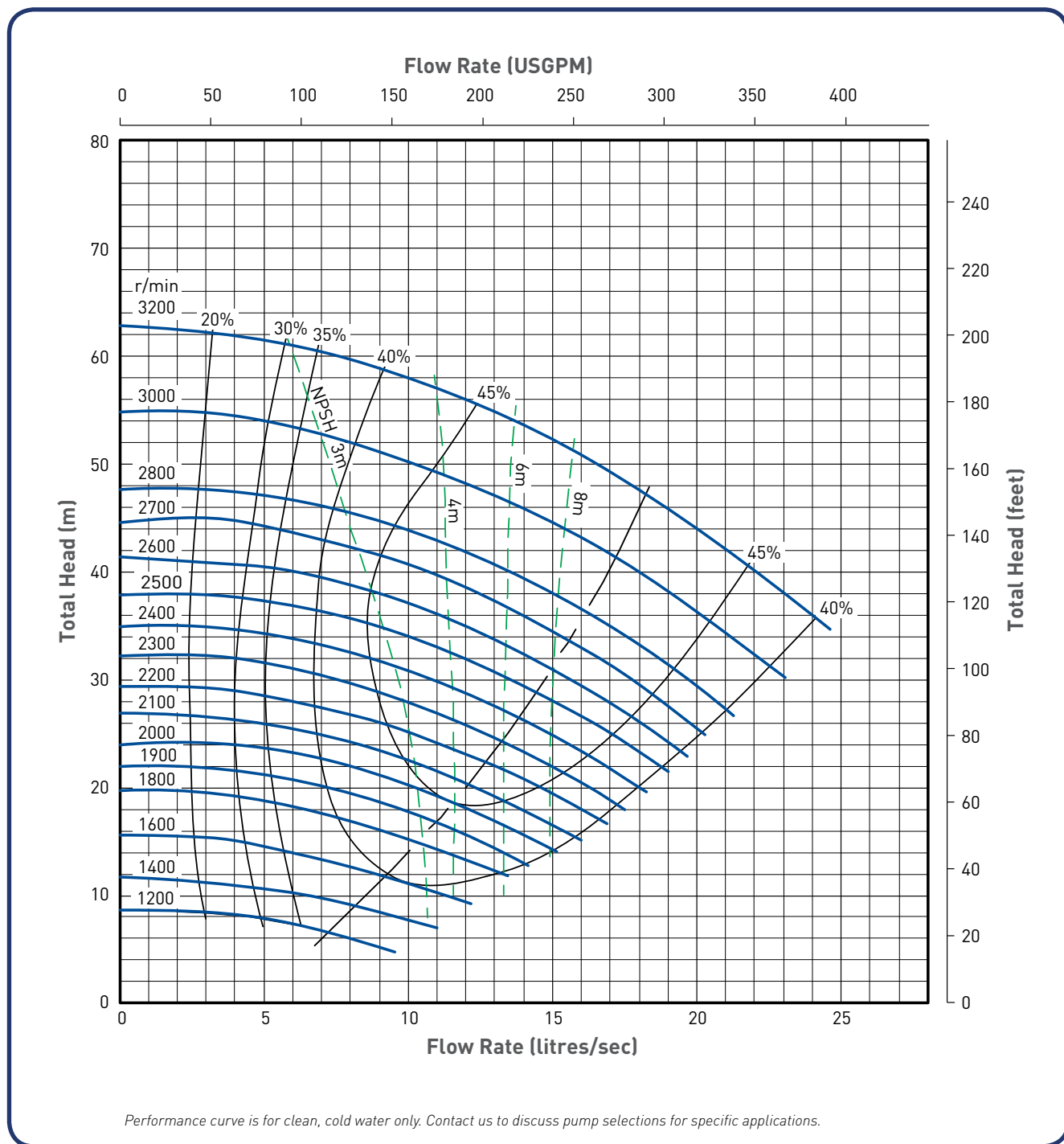

# MAH 2x1.5

## RUBBER LINER AND IMPELLER

### PUMP SPECIFICATIONS

Outlet/ Inlet (mm)	Bearing Frame	Max Power (kW)	Max Particle Size (mm)	Impeller	No. of Vanes	Impeller Material	Impeller/ Vane Dia. (mm)	Wear Liner Material
50/32	B	15	16	B15127	5	Rubber Lined High Tensile Steel	180	Rubber

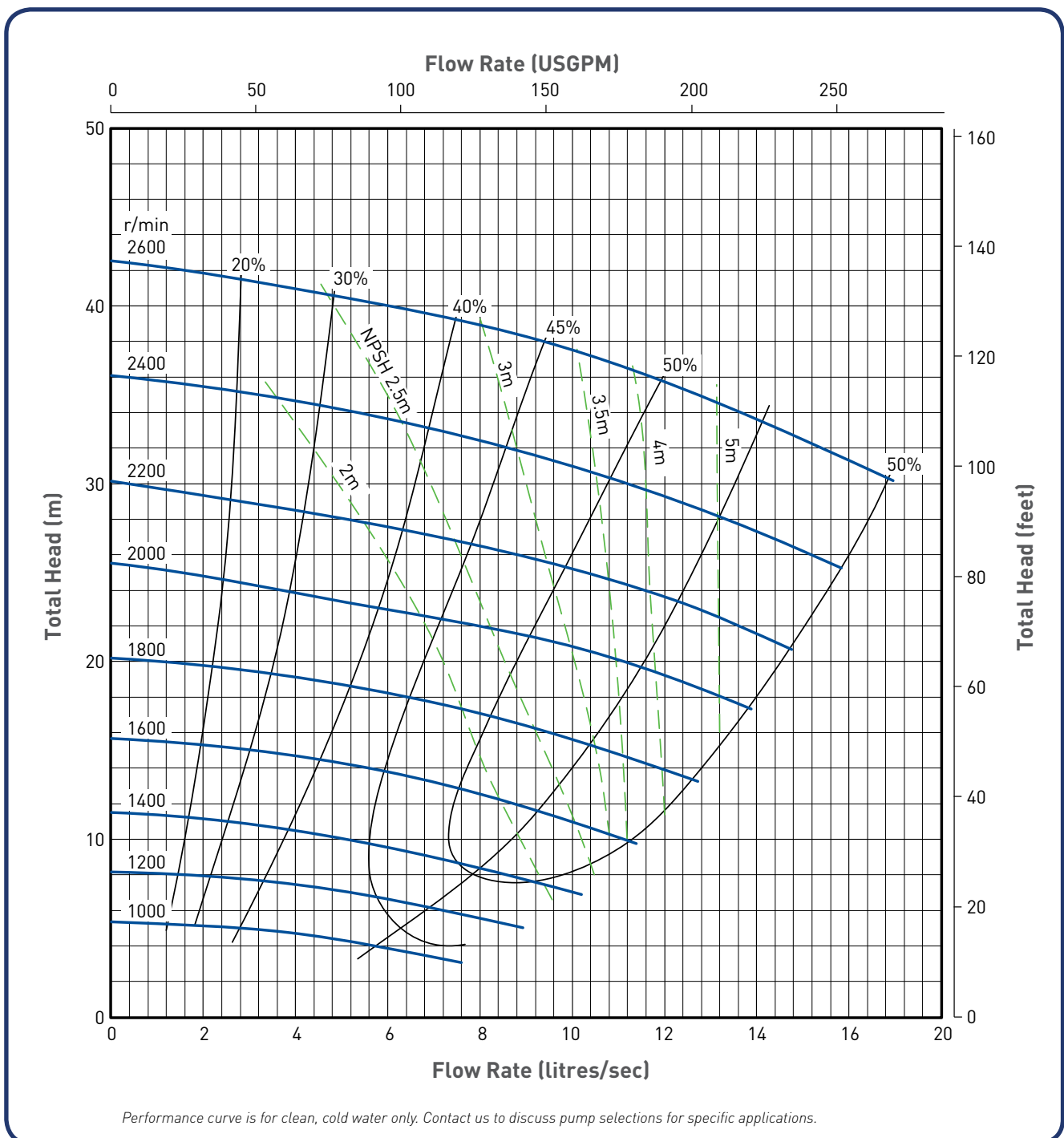

# MAH 3x2

## METAL LINER AND IMPELLER

### PUMP SPECIFICATIONS

Outlet/ Inlet (mm)	Bearing Frame	Max Power (kW)	Max Particle Size (mm)	Impeller	No. of Vanes	Impeller Material	Impeller/ Vane Dia. (mm)	Wear Liner Material
75/50	C	30	25	C2147	5	27% Chrome White Iron	214	27% Chrome White Iron

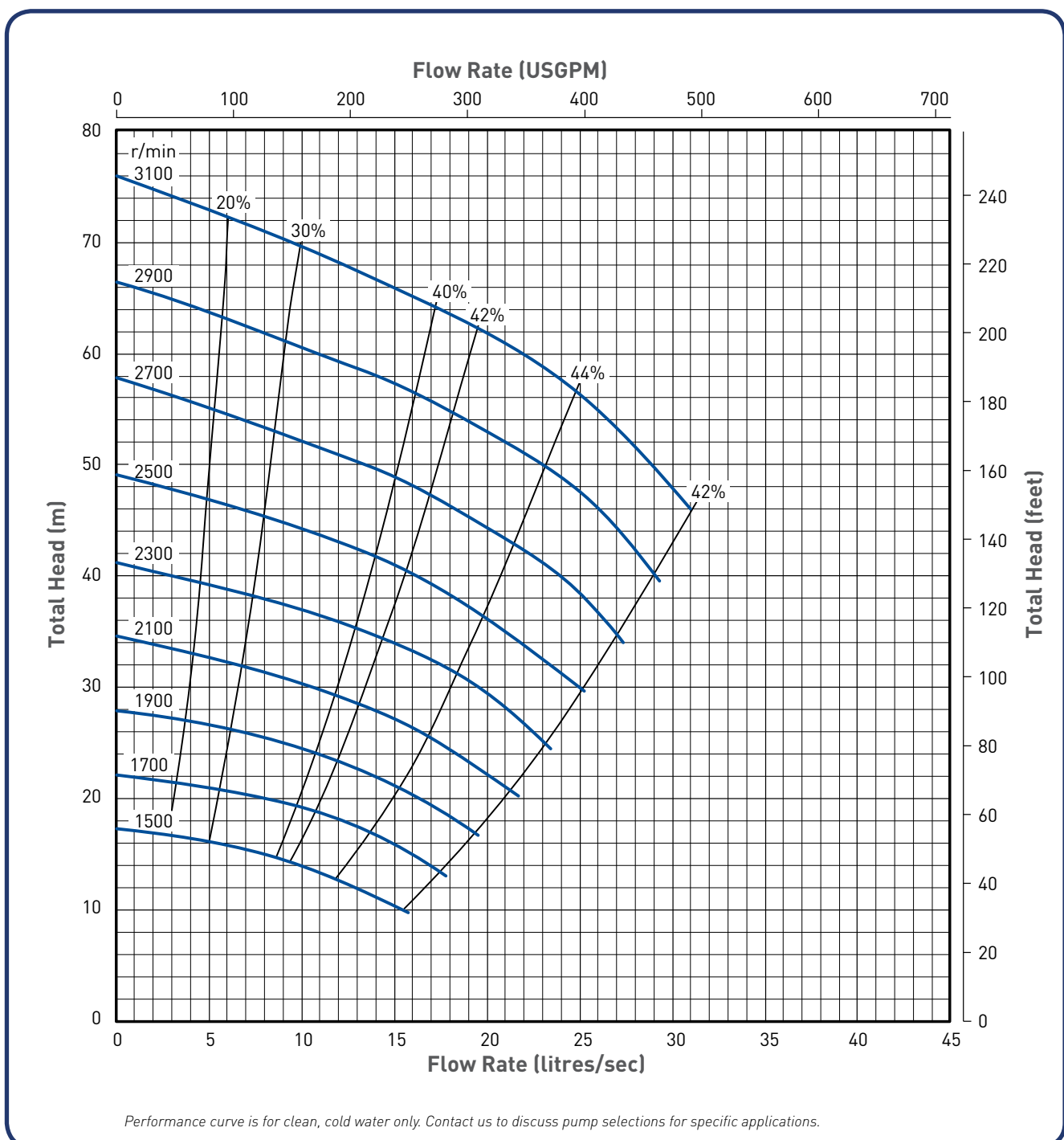

# MAH 3x2

## RUBBER LINER AND IMPELLER

### PUMP SPECIFICATIONS

Outlet/ Inlet (mm)	Bearing Frame	Max Power (kW)	Max Particle Size (mm)	Impeller	No. of Vanes	Impeller Material	Impeller/ Vane Dia. (mm)	Wear Liner Material
75/50	C	30	21	C2127	5	Rubber Lined High Tensile Steel	215	Rubber

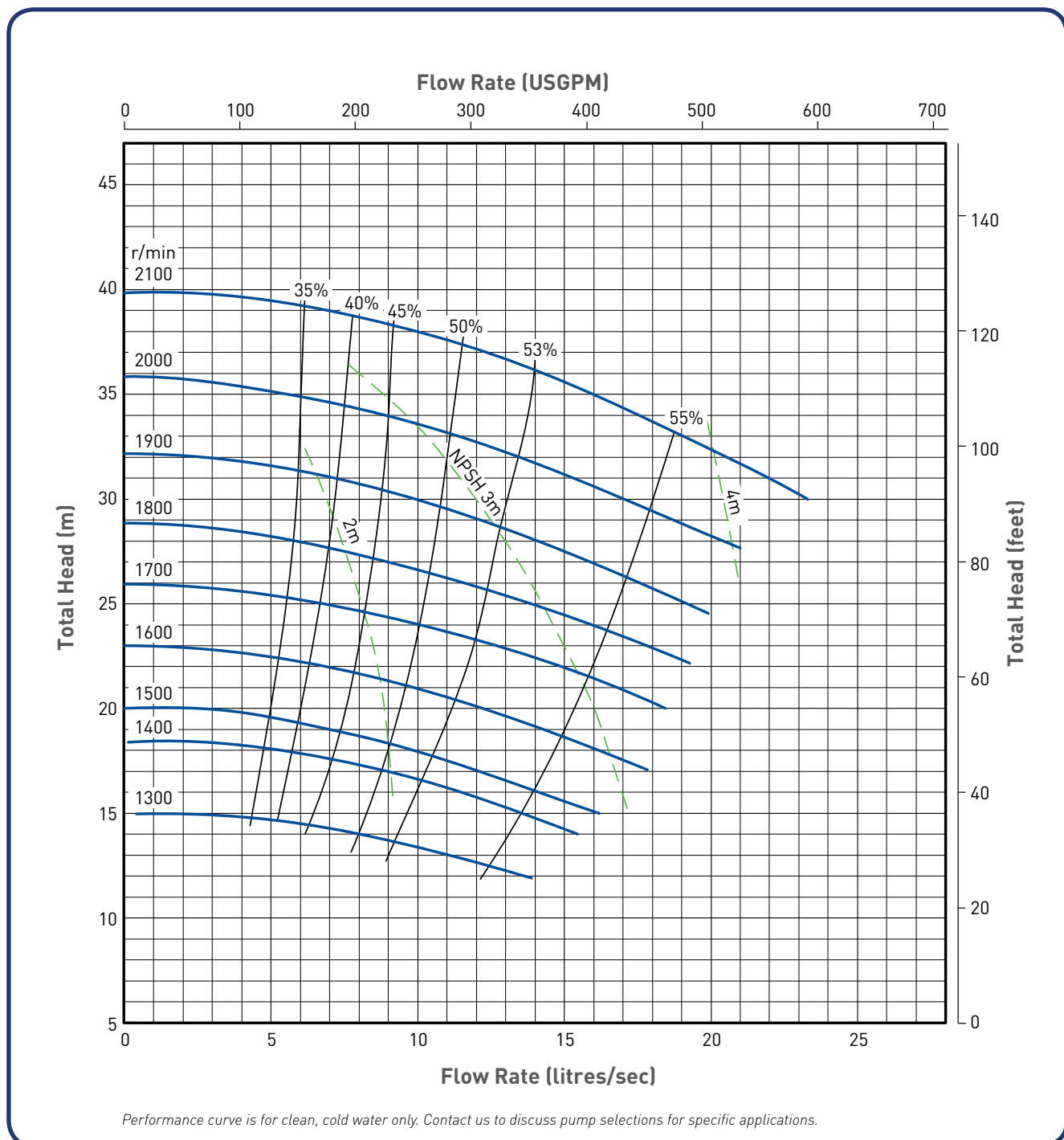

Performance curve is for clean, cold water only. Contact us to discuss pump selections for specific applications.

# MHH 3x2

## HIGH HEAD SLURRY PUMP

### PUMP SPECIFICATIONS

Outlet/ Inlet (mm)	Bearing Frame	Max Power (kW)	Max Particle Size (mm)	Impeller	No. of Vanes	Impeller Material	Impeller/ Vane Dia. (mm)	Wear Liner Material
75/50	D	60	31	MDH2147	5	27% Chrome White Iron	476/457	27% Chrome White Iron
	X (320)	60						

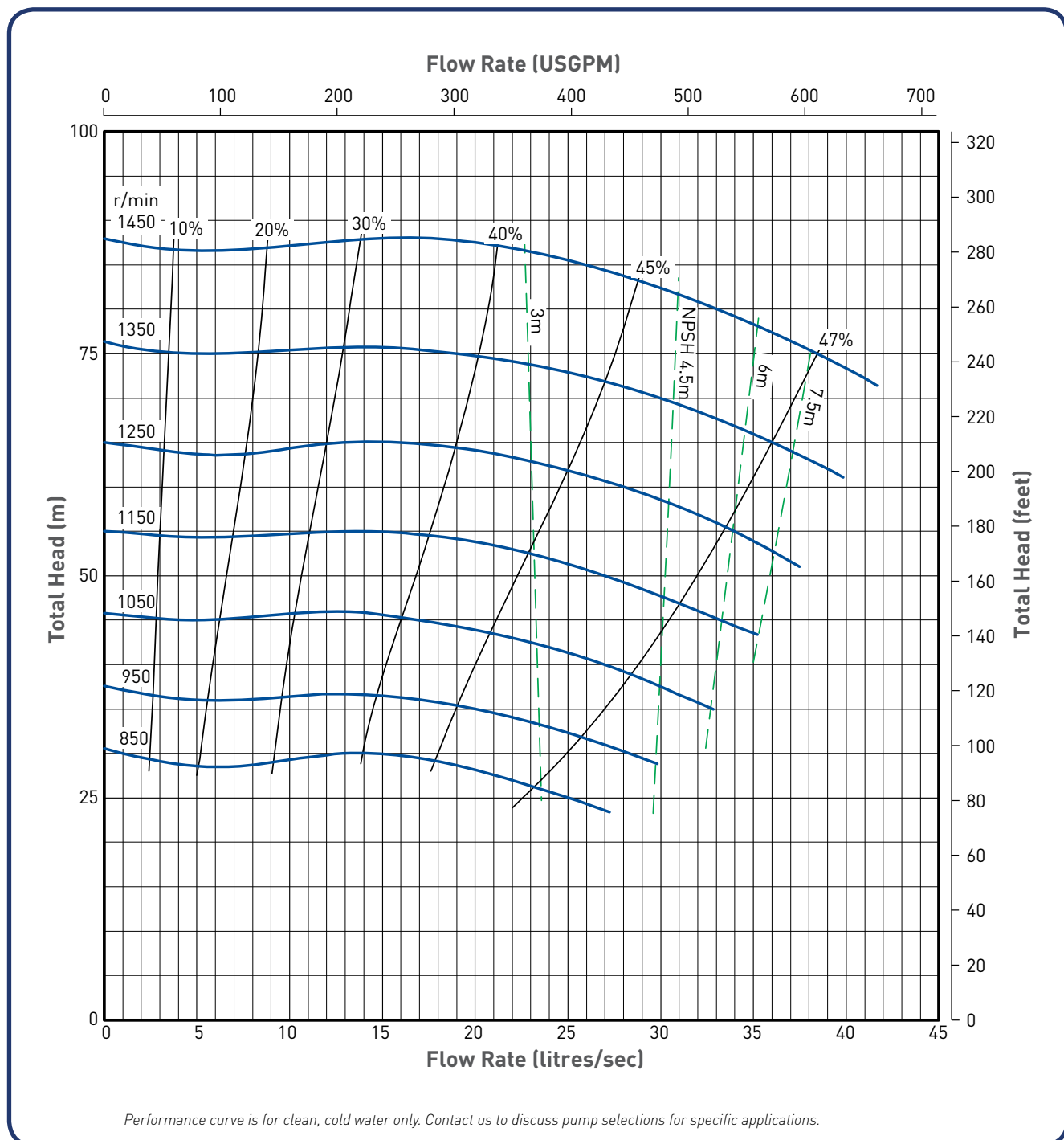

# MAH 4x3

## METAL LINER AND IMPELLER

### PUMP SPECIFICATIONS

Outlet/ Inlet (mm)	Bearing Frame	Max Power (kW)	Max Particle Size (mm)	Impeller	No. of Vanes	Impeller Material	Impeller/ Vane Dia. (mm)	Wear Liner Material
100/75	C	60	18	D3147	5	27% Chrome White Iron	245	27% Chrome White Iron
	D	30						

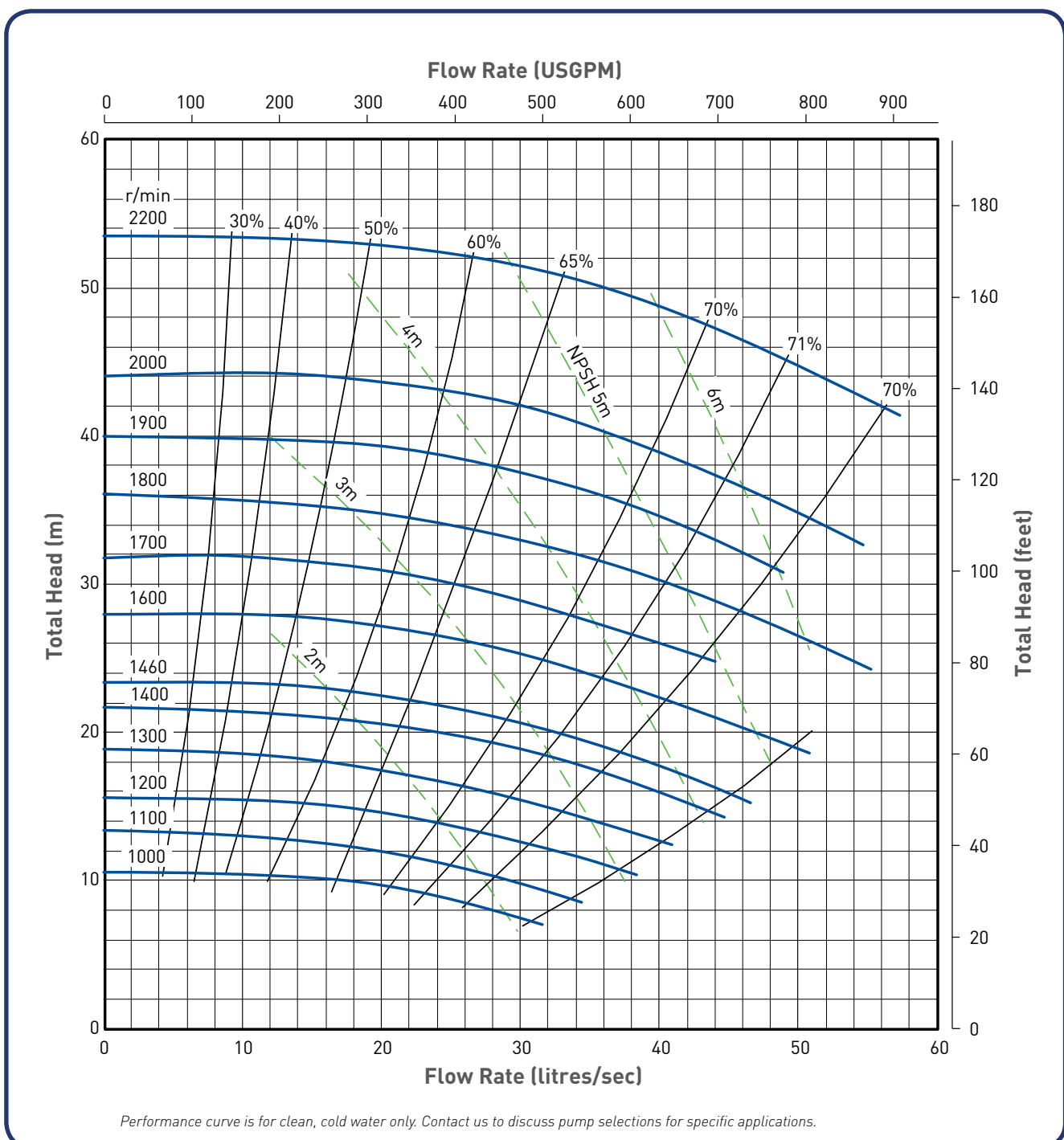

# MAH 4x3

## RUBBER LINER AND IMPELLER

### PUMP SPECIFICATIONS

Outlet/ Inlet (mm)	Bearing Frame	Max Power (kW)	Max Particle Size (mm)	Impeller	No. of Vanes	Impeller Material	Impeller/ Vane Dia. (mm)	Wear Liner Material
100/75	C	30	28	D3147	5	Rubber Lined High Tensile Steel	245	Rubber

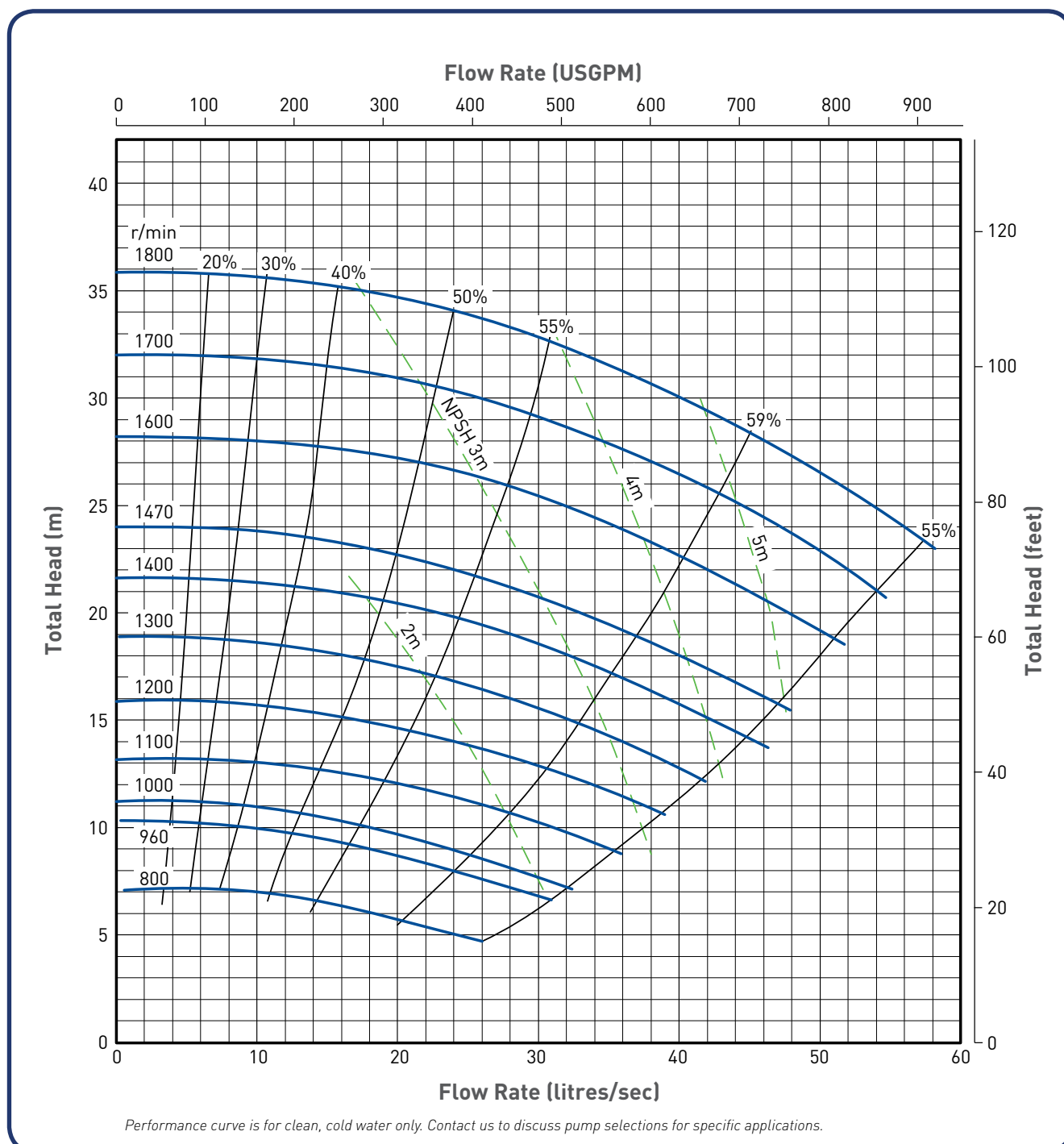

# MHH 4x3

## HIGH HEAD SLURRY PUMP

### PUMP SPECIFICATIONS

Outlet/ Inlet (mm)	Bearing Frame	Max Power (kW)	Max Particle Size (mm)	Impeller	No. of Vanes	Impeller Material	Impeller/ Vane Dia. (mm)	Wear Liner Material
100/75	E	120	38	MEH3147	5	27% Chrome White Iron	518/508	27% Chrome White Iron
	X (406)	300						

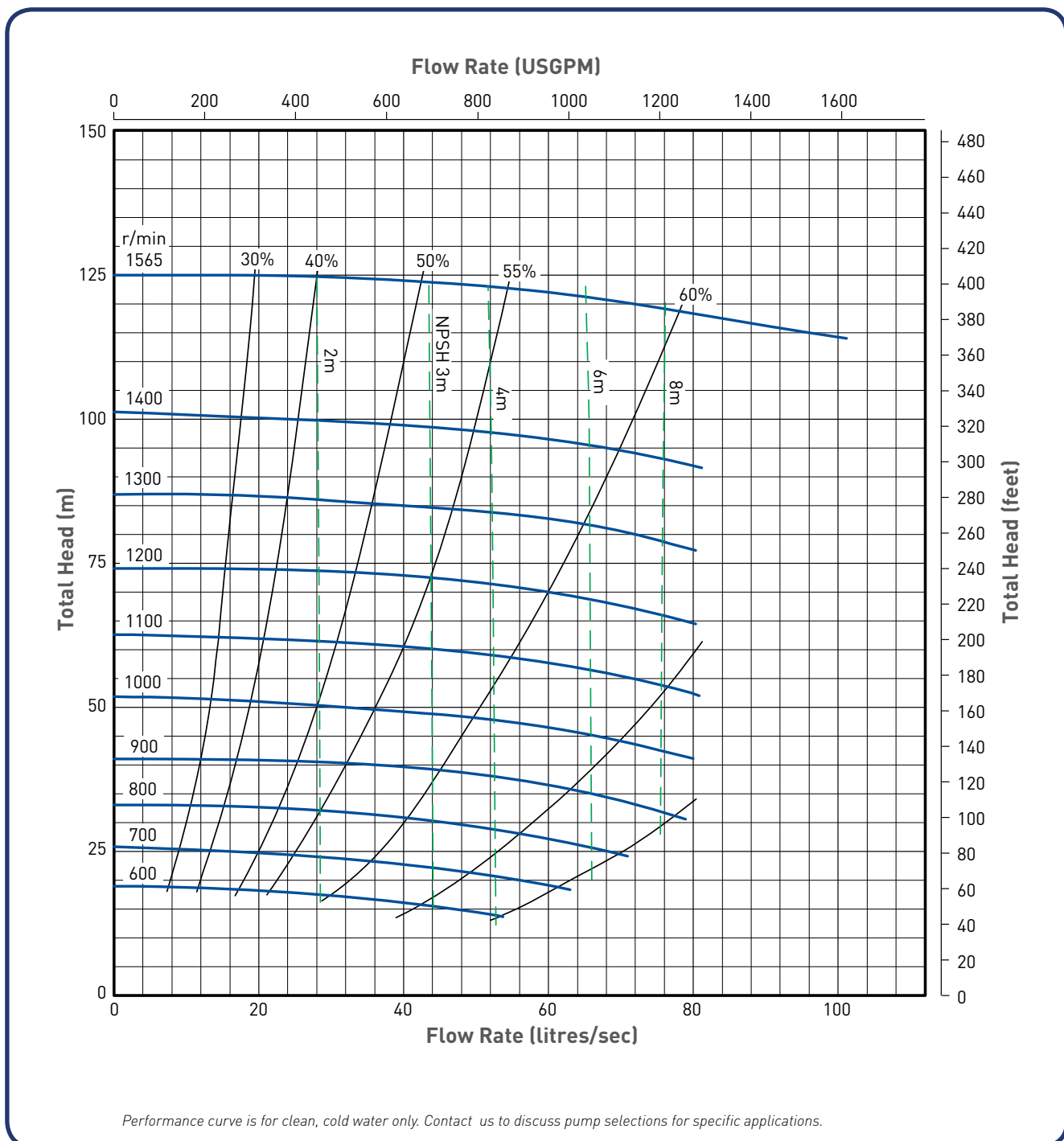

# MAH 6x4

## METAL LINER AND IMPELLER

### PUMP SPECIFICATIONS

Outlet/ Inlet (mm)	Bearing Frame	Max Power (kW)	Max Particle Size (mm)	Impeller	No. of Vanes	Impeller Material	Impeller/ Vane Dia. (mm)	Wear Liner Material
150/100	D	60	44	E4147	5	27% Chrome White Iron	397/365	27% Chrome White Iron
	E	120						
	X (406)	300						

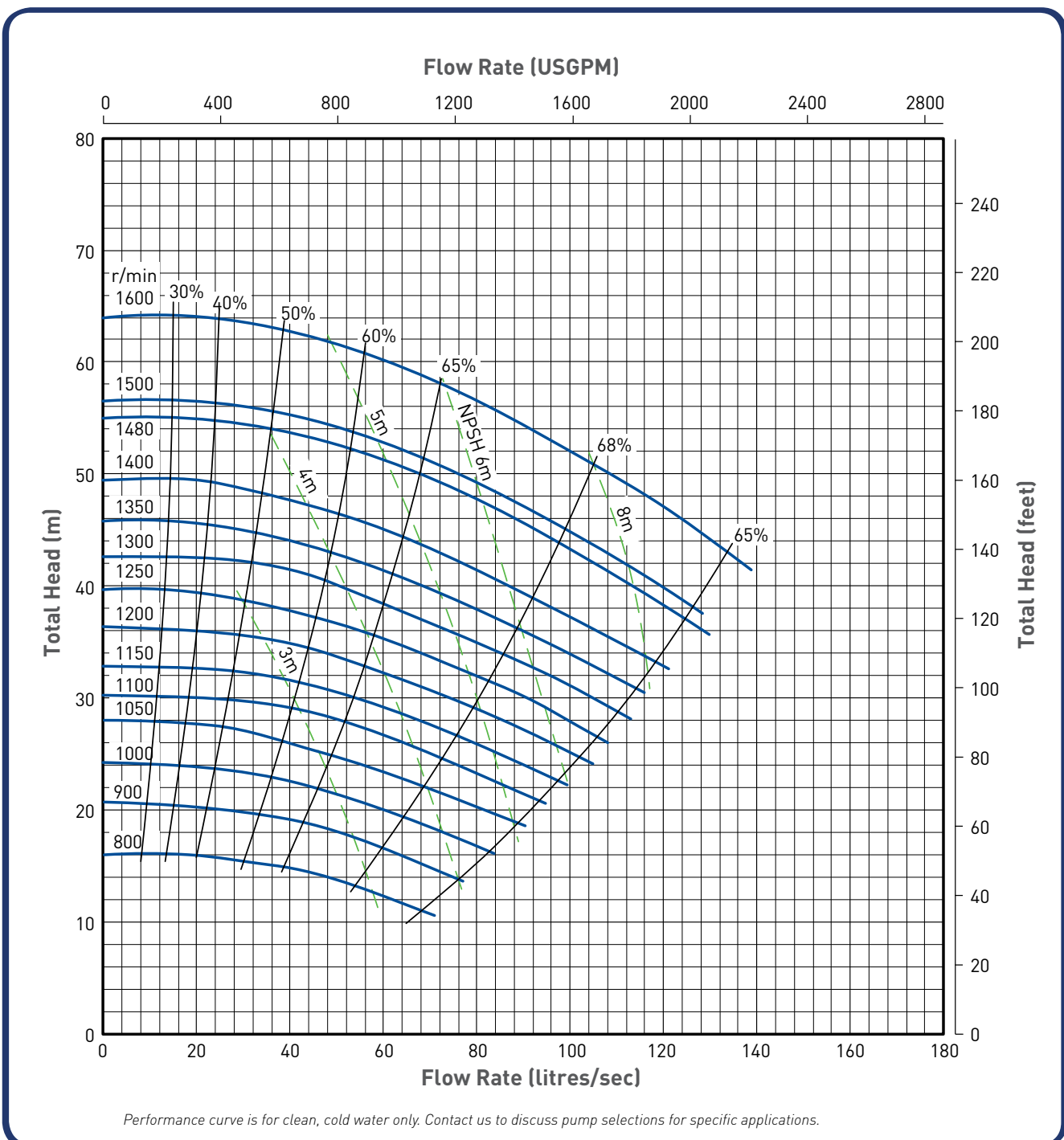

# MAH 6x4

## RUBBER LINER AND IMPELLER

### PUMP SPECIFICATIONS

Outlet/ Inlet (mm)	Bearing Frame	Max Power (kW)	Max Particle Size (mm)	Impeller	No. of Vanes	Impeller Material	Impeller/ Vane Dia. (mm)	Wear Liner Material
150/100	D	60	33	E4147	5	Rubber Lined High Tensile Steel	397/365	Rubber
	E	120						

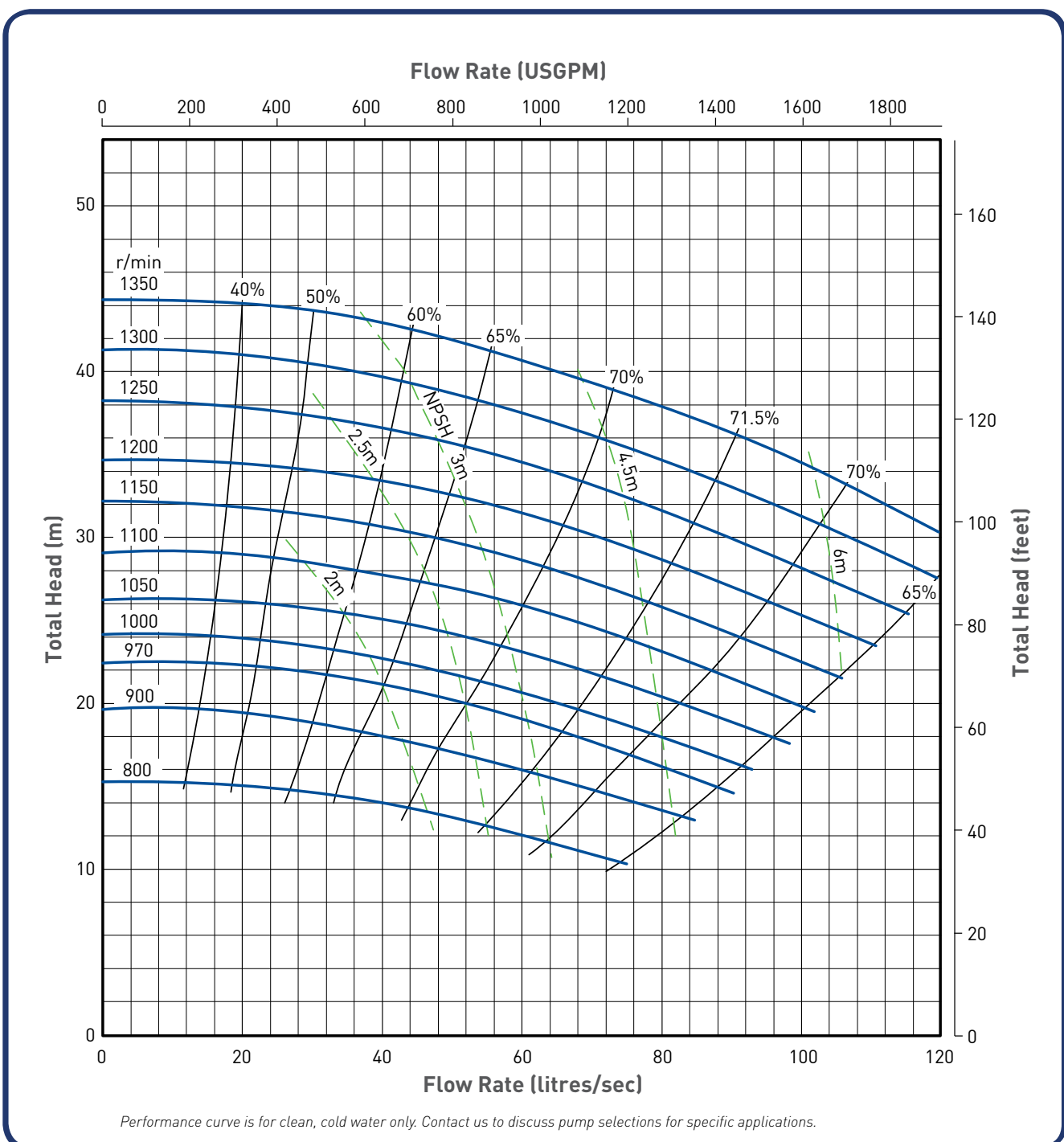

Performance curve is for clean, cold water only. Contact us to discuss pump selections for specific applications.

# MHH 6x4

## HIGH HEAD SLURRY PUMP

### PUMP SPECIFICATIONS

Outlet/ Inlet (mm)	Bearing Frame	Max Power (kW)	Max Particle Size (mm)	Impeller	No. of Vanes	Impeller Material	Impeller/ Vane Dia. (mm)	Wear Liner Material
150/100	F	260	57	MFH4147	5	27% Chrome White Iron	730/709	27% Chrome White Iron

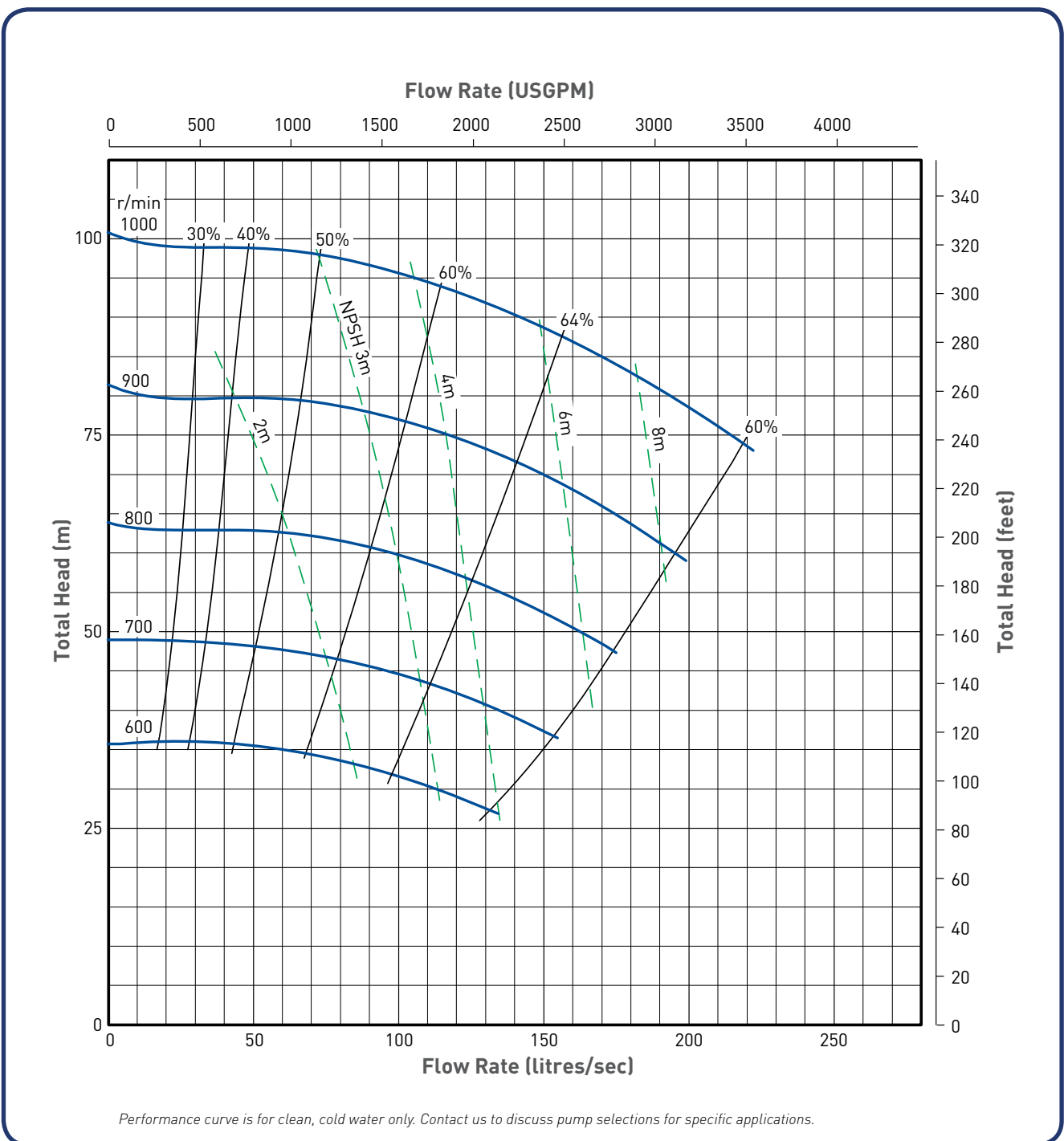

# MAH 8x6

## METAL LINER AND IMPELLER

### PUMP SPECIFICATIONS

Outlet/ Inlet (mm)	Bearing Frame	Max Power (kW)	Max Particle Size (mm)	Impeller	No. of Vanes	Impeller Material	Impeller/ Vane Dia. (mm)	Wear Liner Material
200/150	E	120	63	F6147	5	27% Chrome White Iron	510	27% Chrome White Iron
	R	300						
	X (406)	300						

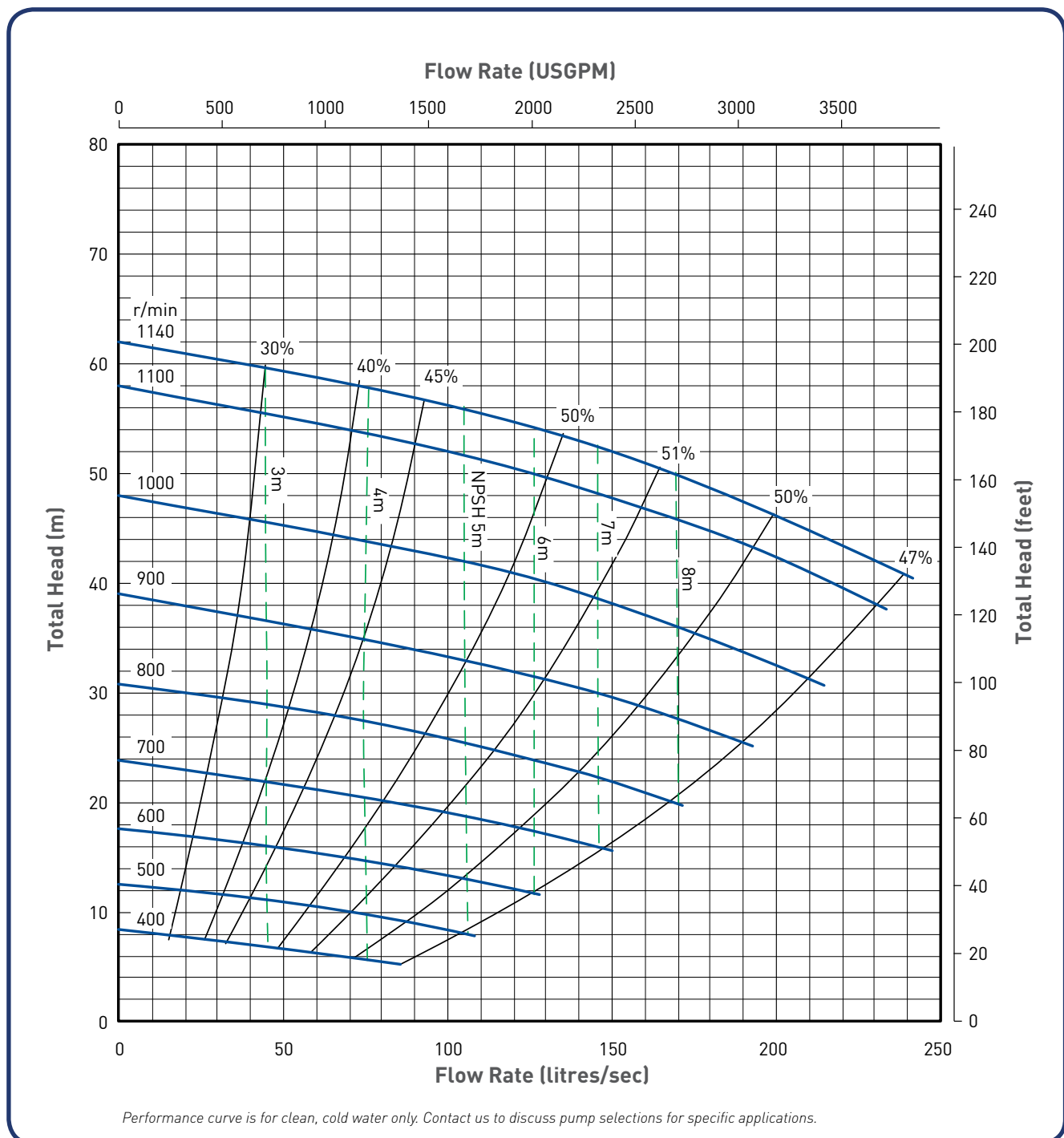

# MAH 8x6

## RUBBER LINER AND IMPELLER

### PUMP SPECIFICATIONS

Outlet/ Inlet (mm)	Bearing Frame	Max Power (kW)	Max Particle Size (mm)	Impeller	No. of Vanes	Impeller Material	Impeller/ Vane Dia. (mm)	Wear Liner Material
200/150	E	120	59	F6147	5	Rubber Lined High Tensile Steel	510	Rubber
	R	300						

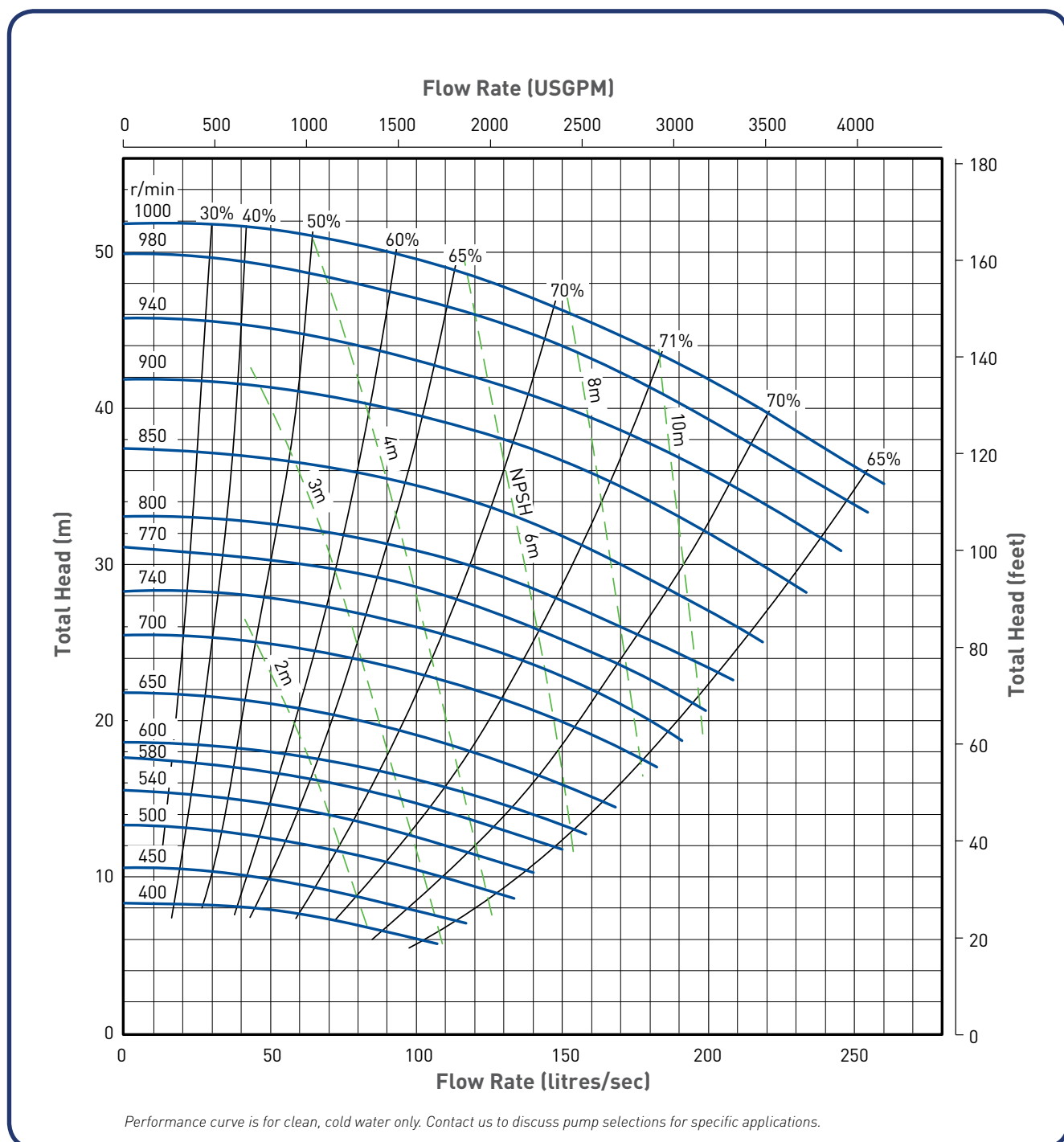

# MHH 8x6

## HIGH HEAD SLURRY PUMP

### PUMP SPECIFICATIONS

Outlet/ Inlet (mm)	Bearing Frame	Max Power (kW)	Max Particle Size (mm)	Impeller	No. of Vanes	Impeller Material	Impeller/ Vane Dia. (mm)	Wear Liner Material
200/150	S	560	70	FH6145	5	27% Chrome White Iron	740/711	27% Chrome White Iron
	T	560						

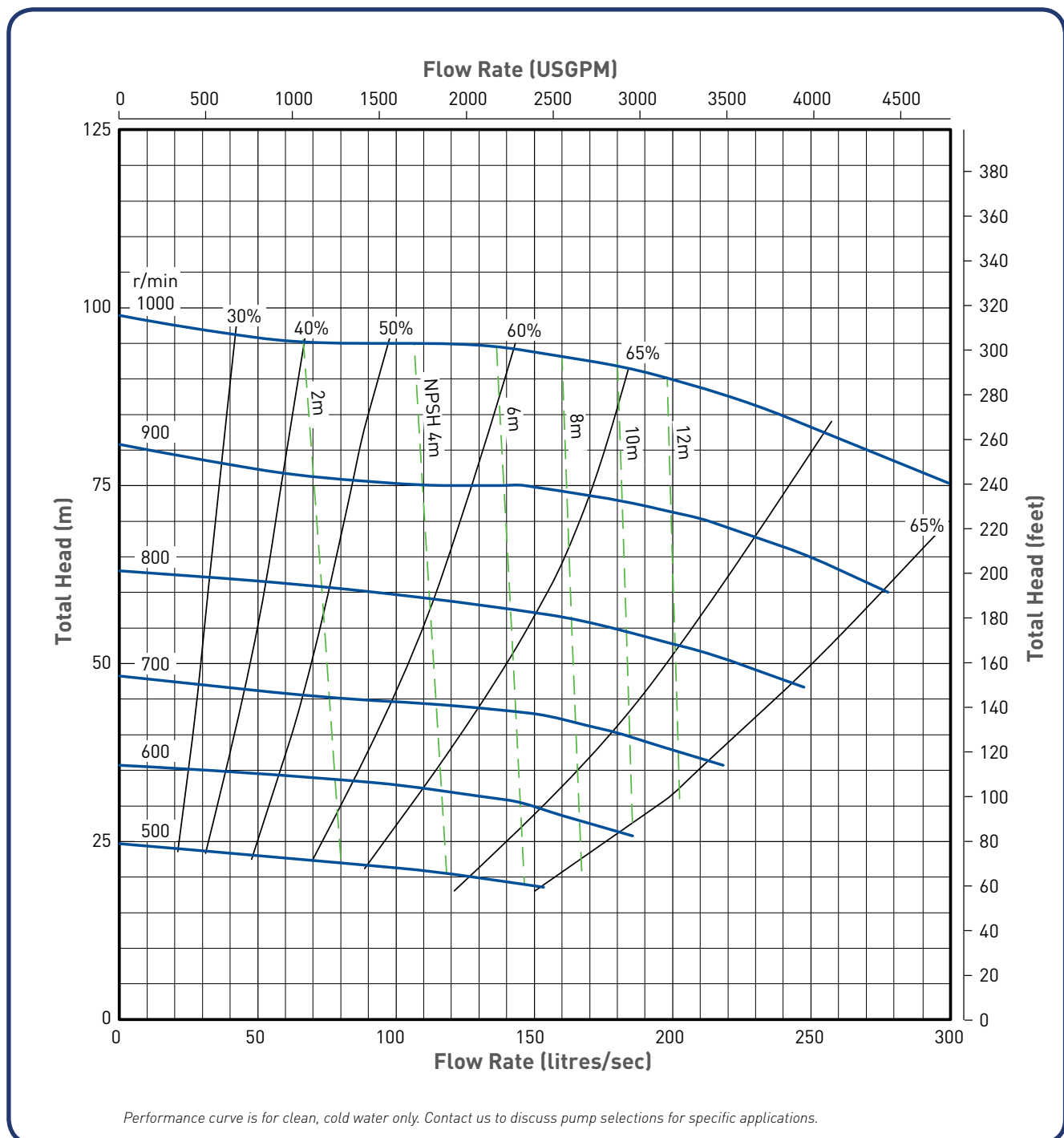

# MAH 10x8

## METAL LINER AND IMPELLER

### PUMP SPECIFICATIONS

Outlet/ Inlet (mm)	Bearing Frame	Max Power (kW)	Max Particle Size (mm)	Impeller	No. of Vanes	Impeller Material	Impeller/ Vane Dia. (mm)	Wear Liner Material
250/200	F	260	76	FAM8147 G8147	5	27% Chrome White Iron	686	27% Chrome White Iron
	ST	560						
	X (743)	710						

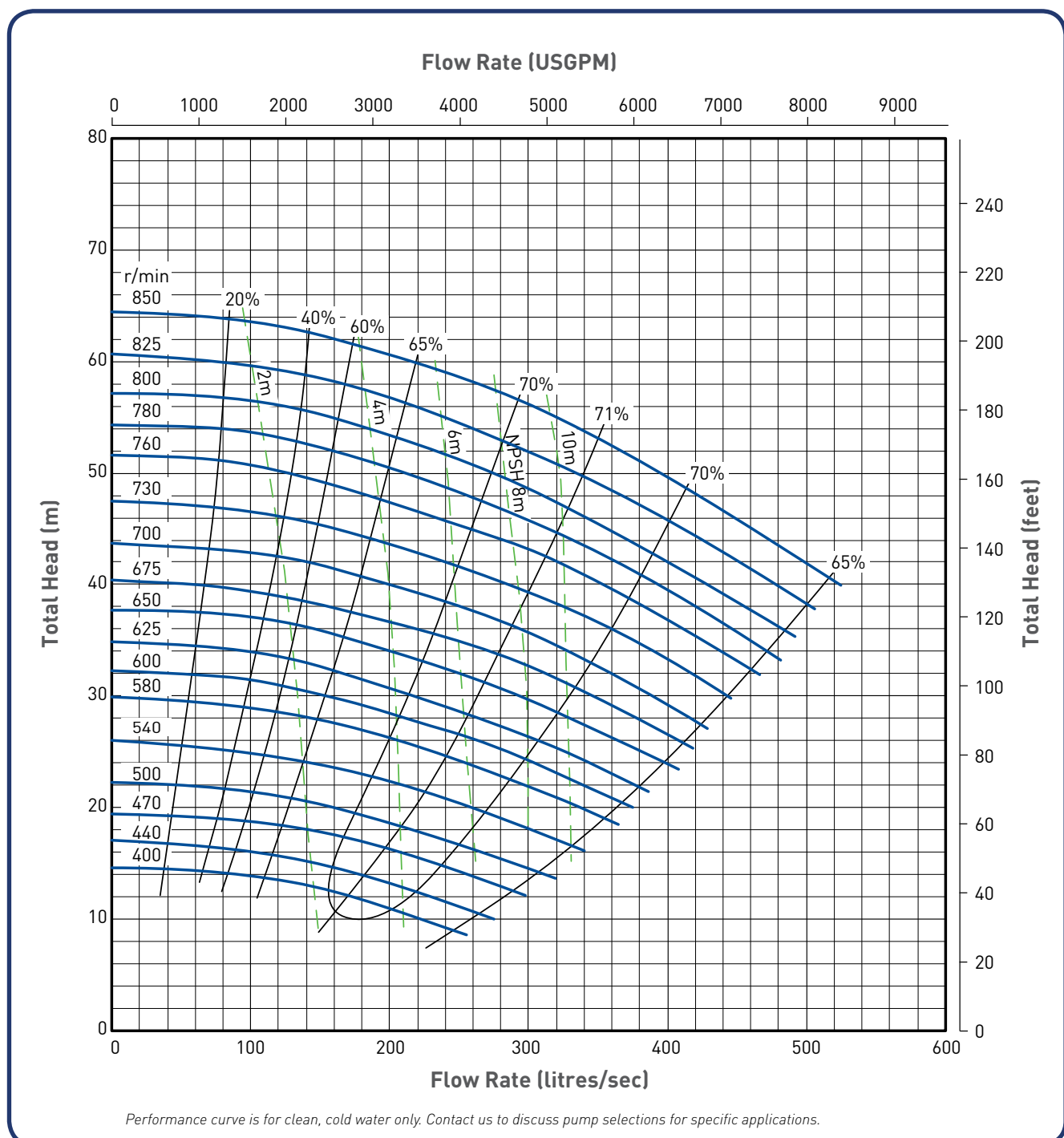

# MAH 10x8

## RUBBER LINER AND IMPELLER

### PUMP SPECIFICATIONS

Outlet/ Inlet (mm)	Bearing Frame	Max Power (kW)	Max Particle Size (mm)	Impeller	No. of Vanes	Impeller Material	Impeller/ Vane Dia. (mm)	Wear Liner Material
250/200	F	260	76	FAM8147	5	Rubber Lined High Tensile Steel	686	Rubber
	ST	560						

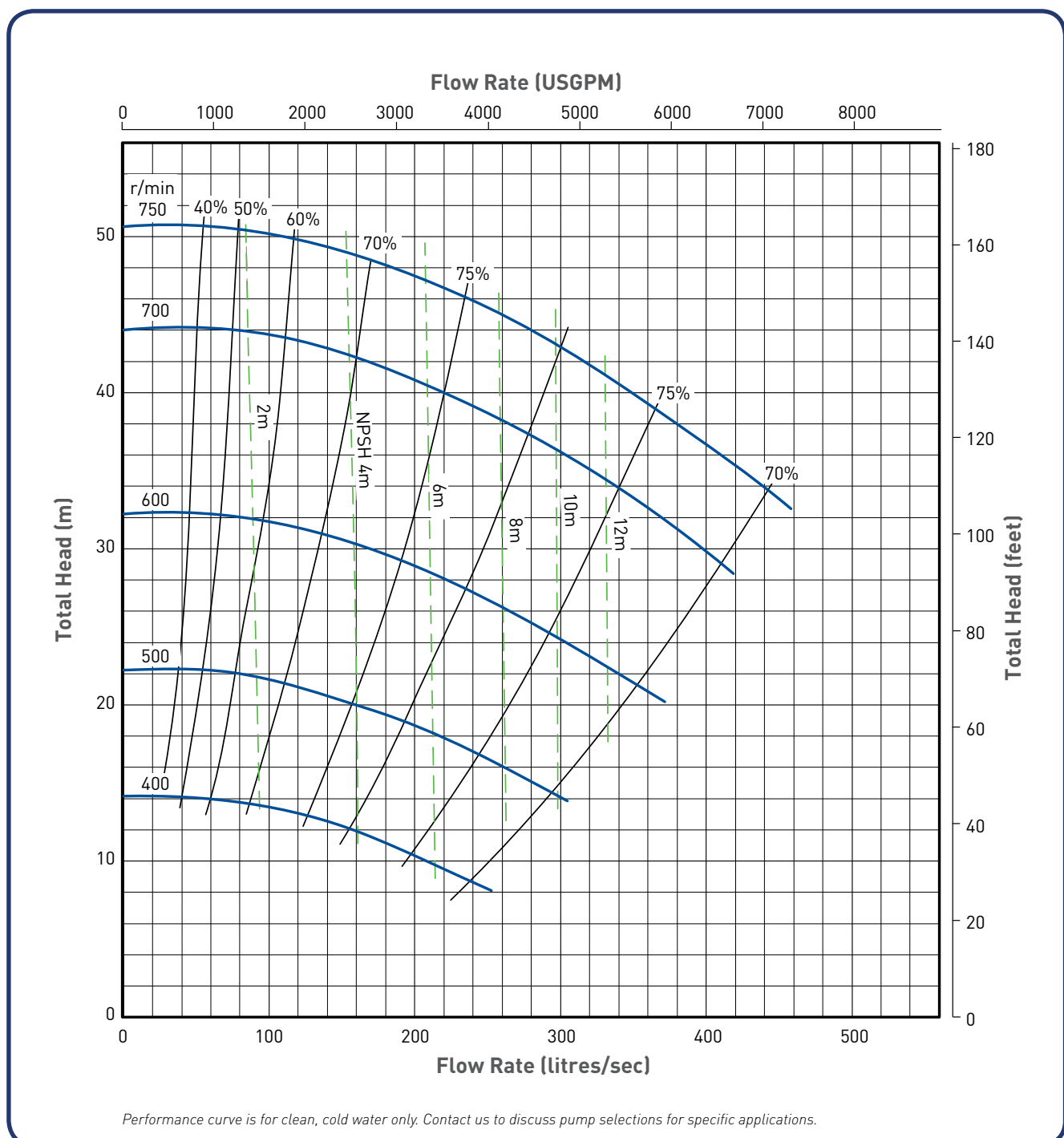

Performance curve is for clean, cold water only. Contact us to discuss pump selections for specific applications.

# MAH 12x10

## METAL LINER AND IMPELLER

### PUMP SPECIFICATIONS

Outlet/ Inlet (mm)	Bearing Frame	Max Power (kW)	Max Particle Size (mm)	Impeller	No. of Vanes	Impeller Material	Impeller/ Vane Dia. (mm)	Wear Liner Material
300/250	ST	560	86	FAM10147 G10147	5	27% Chrome White Iron	762	27% Chrome White Iron
	X (743)	560						

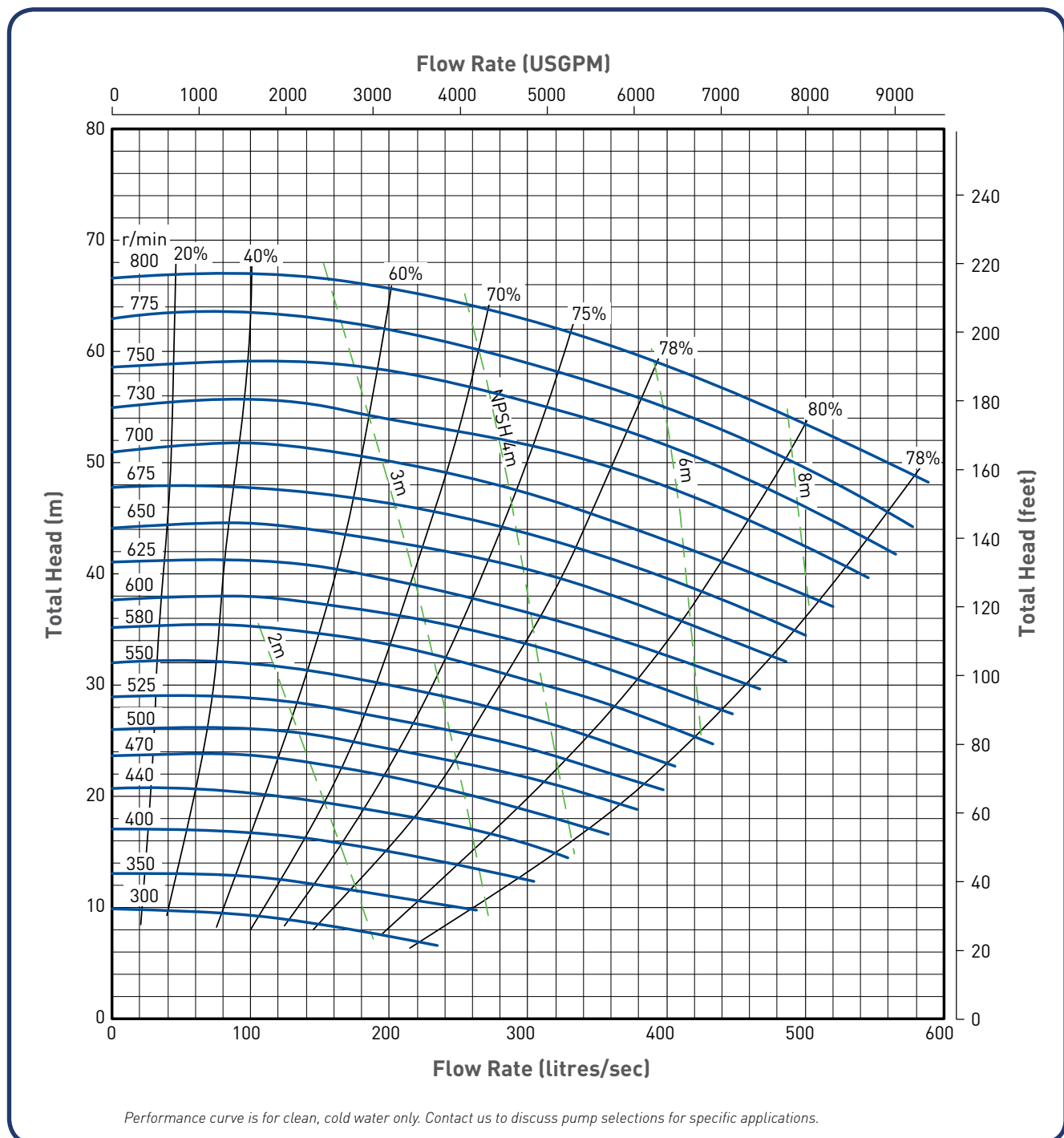

# MAH 12x10

## RUBBER LINER AND IMPELLER

### PUMP SPECIFICATIONS

Outlet/ Inlet (mm)	Bearing Frame	Max Power (kW)	Max Particle Size (mm)	Impeller	No. of Vanes	Impeller Material	Impeller/ Vane Dia. (mm)	Wear Liner Material
300/250	ST	560	86	G10147	5	Rubber Lined High Tensile Steel	762	Rubber
	G	600						

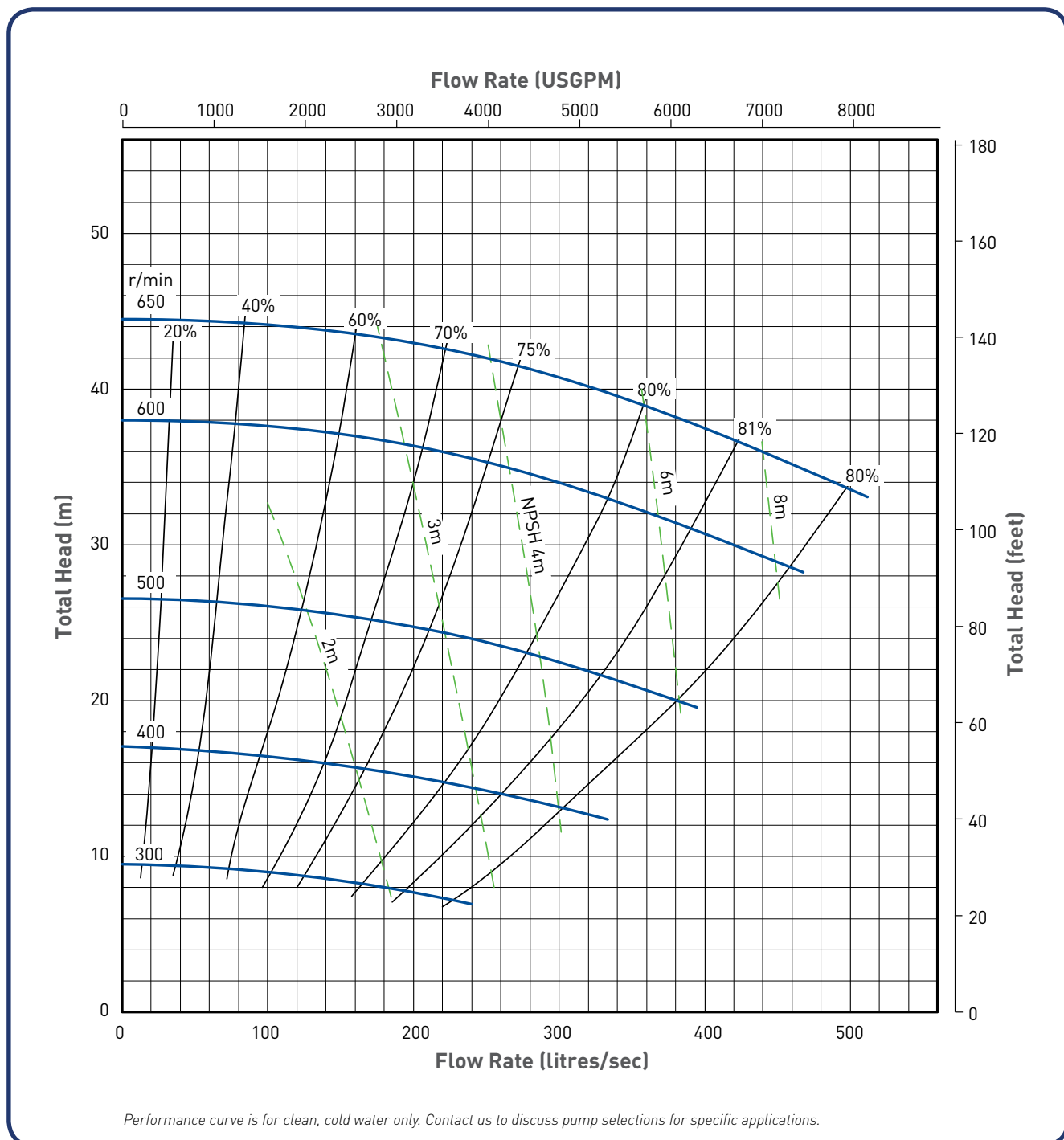

# MAH 14x12

## METAL LINER AND IMPELLER

### PUMP SPECIFICATIONS

Outlet/ Inlet (mm)	Bearing Frame	Max Power (kW)	Max Particle Size (mm)	Impeller	No. of Vanes	Impeller Material	Impeller/ Vane Dia. (mm)	Wear Liner Material
350/300	ST	560	90	FAM12147 G12147	5	27% Chrome White Iron	965	27% Chrome White Iron
	T	1200						

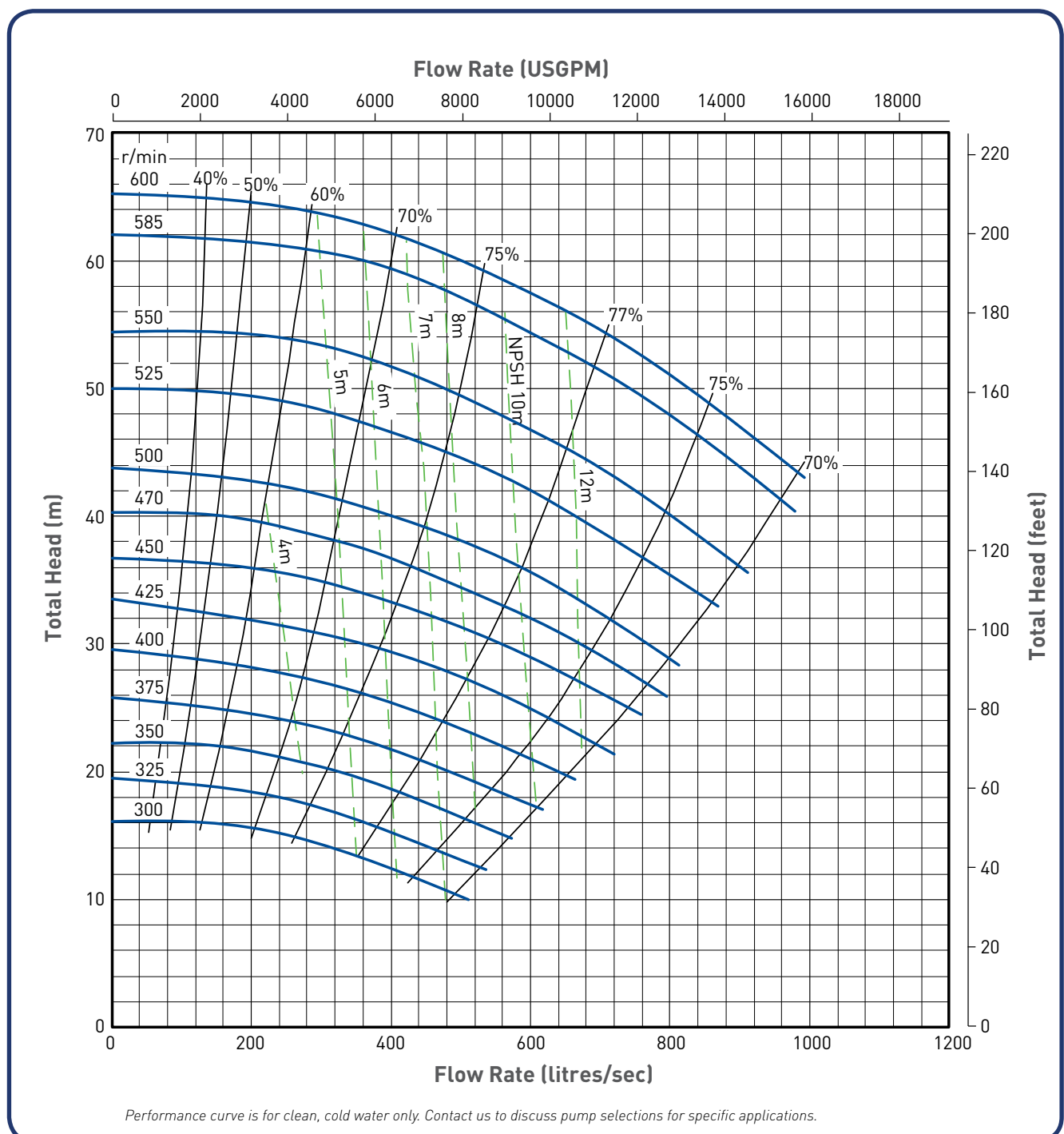

# MAH 14x12

## RUBBER LINER AND IMPELLER

### PUMP SPECIFICATIONS

Outlet/ Inlet (mm)	Bearing Frame	Max Power (kW)	Max Particle Size (mm)	Impeller	No. of Vanes	Impeller Material	Impeller/ Vane Dia. (mm)	Wear Liner Material
350/300	ST	560	104	G12147	5	Rubber Lined High Tensile Steel	965	Rubber
	G	600						

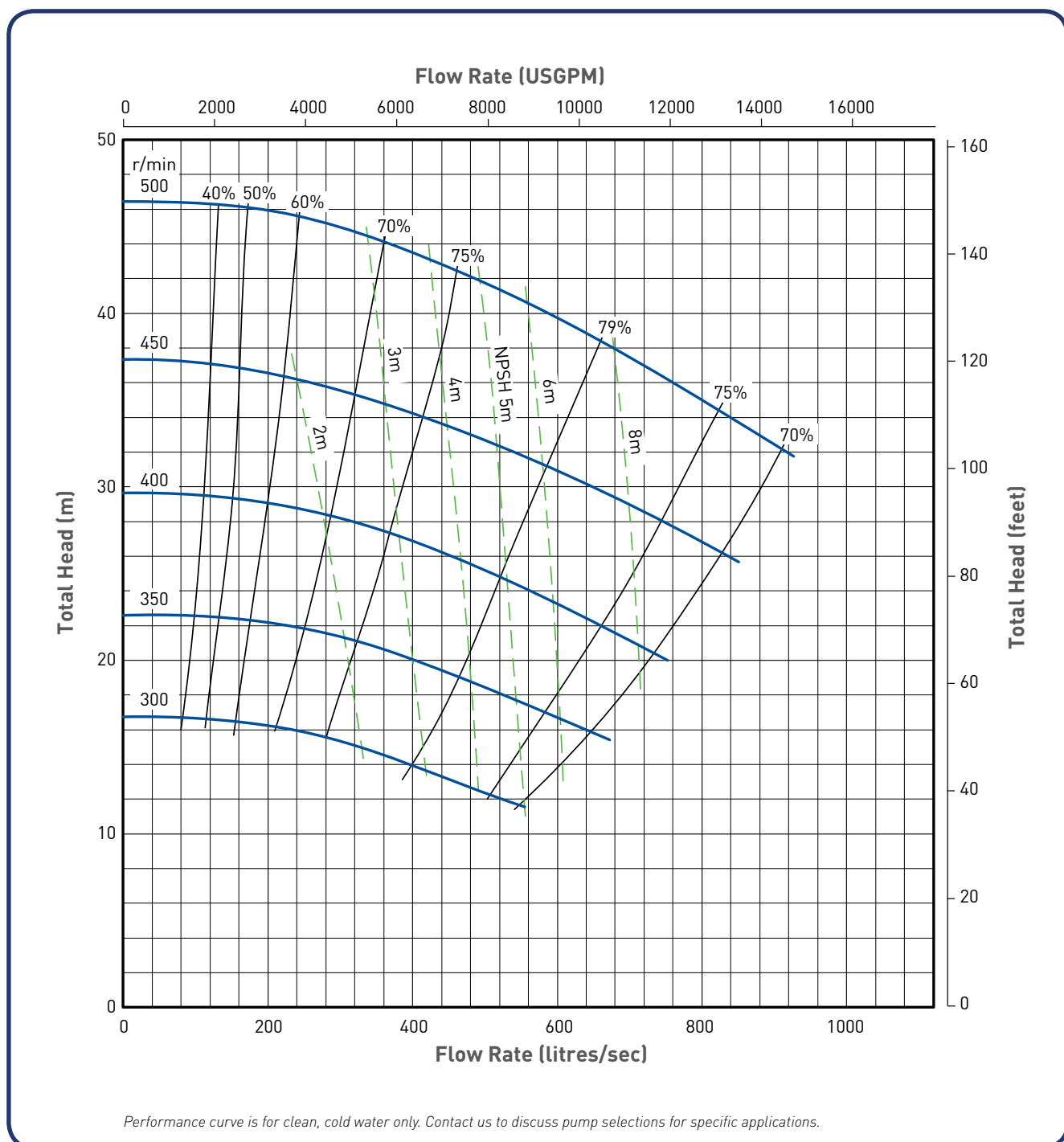

# DIMENSIONS

## GENERAL ARRANGEMENT DRAWING

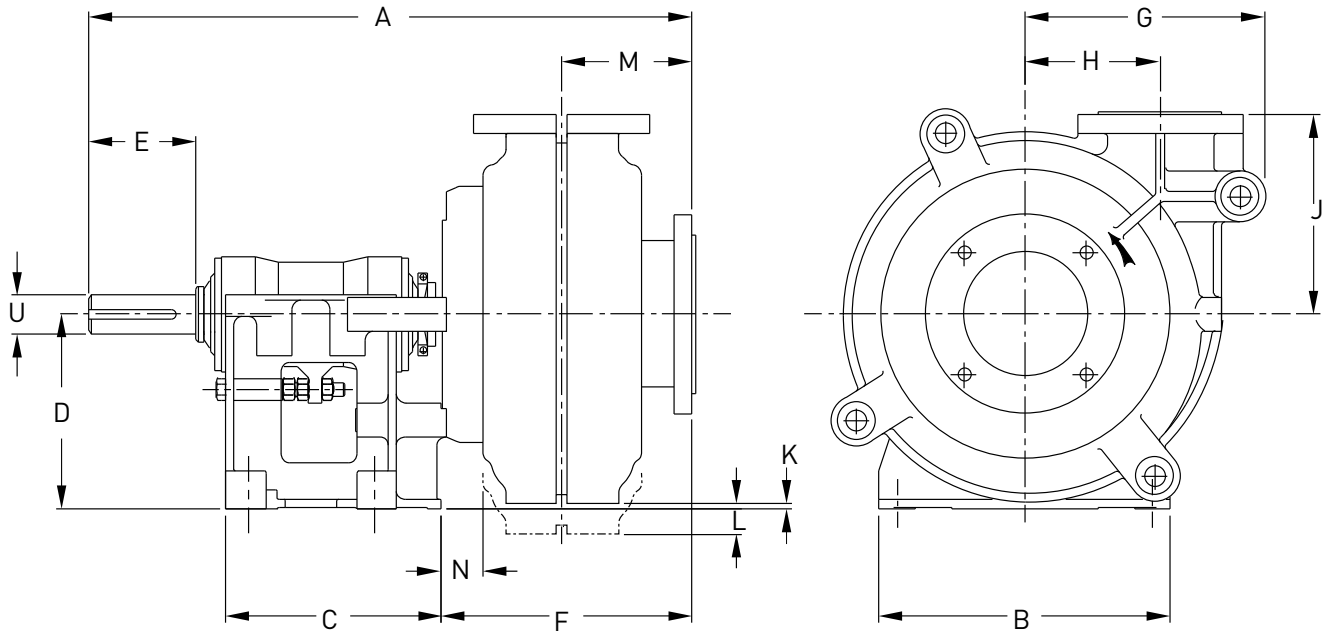

Note: Drawing is indicative only and does not accurately represent how pumps of all sizes will appear.

Model	Dimensions (mm)															Weight (kg)	
	A	B	C	D	Key	E	F	G	H	J	K	L	M	N	U	Metal	Rubber
1.5x1 B	583	295	248	197	8x7	79	206	181	98	171	46	-	106	19	28	88	77
1.5x1 C - HH	759	406	311	254	12x8	121	306	270	194	254	-	11	121	66	42	318	-
2x1.5 B	592	295	248	197	8x7	79	217	203	114	184	33	-	114	22	28	156	118
3x2 C	768	406	311	254	12x8	121	280	238	138	210	71	-	151	40	42	197	154
3x2 D - HH	986	492	364	330	18x11	164	389	384	254	368	-	51	203	83	65	750	-
4x3 C	843	406	311	254	12x8	121	353	292	149	262	24	-	187	54	42	249	236
4x3 D	943	492	364	330	18x11	164	353	292	149	262	100	-	187	52	65	318	290
4x3 E - HH	1240	622	448	457	22x14	222	492	492	330	432	-	12	248	79	80	1250	-
6x4 D	1021	492	364	330	18x11	164	424	406	229	338	11	-	219	65	65	669	454
6x4 E	1178	622	448	457	22x14	222	433	406	229	338	138	-	219	75	80	885	635
6x4 F - HH	1556	857	634	610	28x16	279	585	616	413	546	-	134	305	75	100	3420	-
8x6 E	1302	622	448	457	22x14	222	557	551	318	460	-	62	292	82	80	1497	982
8x6 F	1507	857	635	610	28x16	279	539	551	318	460	90	-	292	65	100	1814	1390
8x6 T - HH	2275	1150	1040	650	36x20	350	852	835	584	813	-	160	394	-	150	6900	-
10x8 F	1646	991	705	610	28x16	279	683	673	419	635	-	12	333	134	100	3193	2581
10x8 ST	1748	1150	780	650	32x18	280	692	673	419	635	27	-	333	143	120	3742	3130
12x10 F	1721	991	705	610	28x16	279	753	756	464	673	-	104	381	108	100	3760	2808
12x10 ST	1816	1150	780	650	32x18	280	762	755	464	673	-	65	381	117	120	4309	3357
14x12 F	1772	991	705	610	28x16	279	803	937	629	832	-	263	406	105	100	5847	4123
14x12 ST	1873	1150	780	650	32x18	280	812	937	629	832	-	224	406	114	120	6396	4672
16x14 TU	2320	1460	1050	900	36x20	350	953	1048	660	889	-	84	451	167	150	9979	-
20x18 TU	2475	1460	1050	900	36x20	350	1100	1420	940	1230	-	420	480	210	150	18864	15921

# MATERIALS

## METAL LINED PUMPS

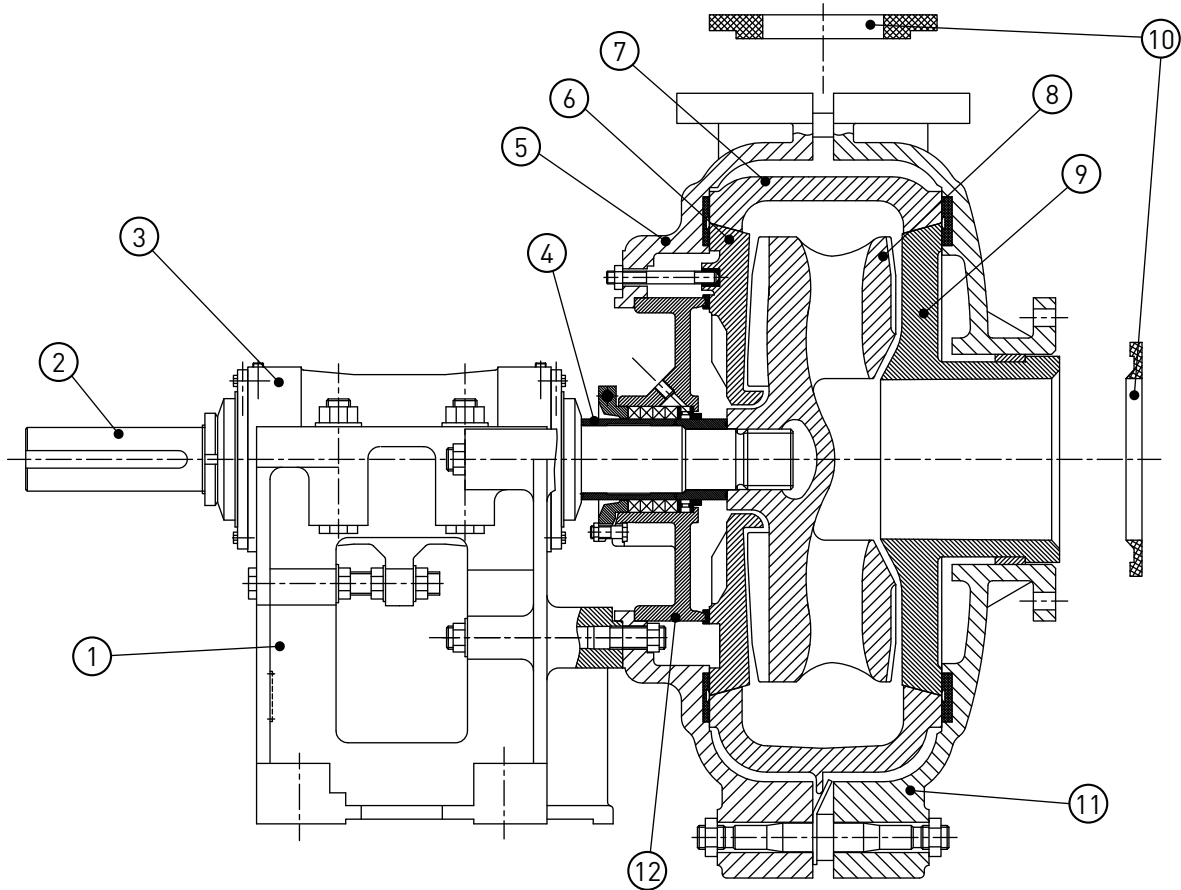

No.	Part Description	Material Specification
1	Base	Cast Iron
2	Shaft	4140 High Tensile Steel*
3	Bearing Assembly	Timkin (Cast Iron Body)
4	Shaft Sleeve	420 Stainless Steel
5	Pump Casing	Cast Iron
6	Frame Plate Liner	27% Chrome White Iron
7	Volute Liner	27% Chrome White Iron
8	Impeller	27% Chrome White Iron
9	Throat Bush	27% Chrome White Iron
10	Joint Rings	Rubber
11	Cover Plate	Cast Iron
12	Stuffing Box	Cast Iron
13	Expeller	27% Chrome White Iron
14	Expeller Ring	Natural Rubber
	Bolts	Zinc Plated Steel
	O-rings	Nitrile Rubber
	Seals	Rubber

\* Other shaft material options are available.

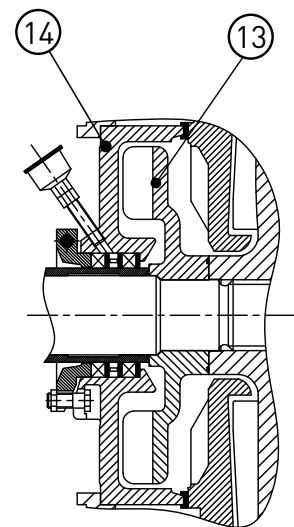

**METAL EXPELLER**

# MATERIALS

## RUBBER LINED PUMPS

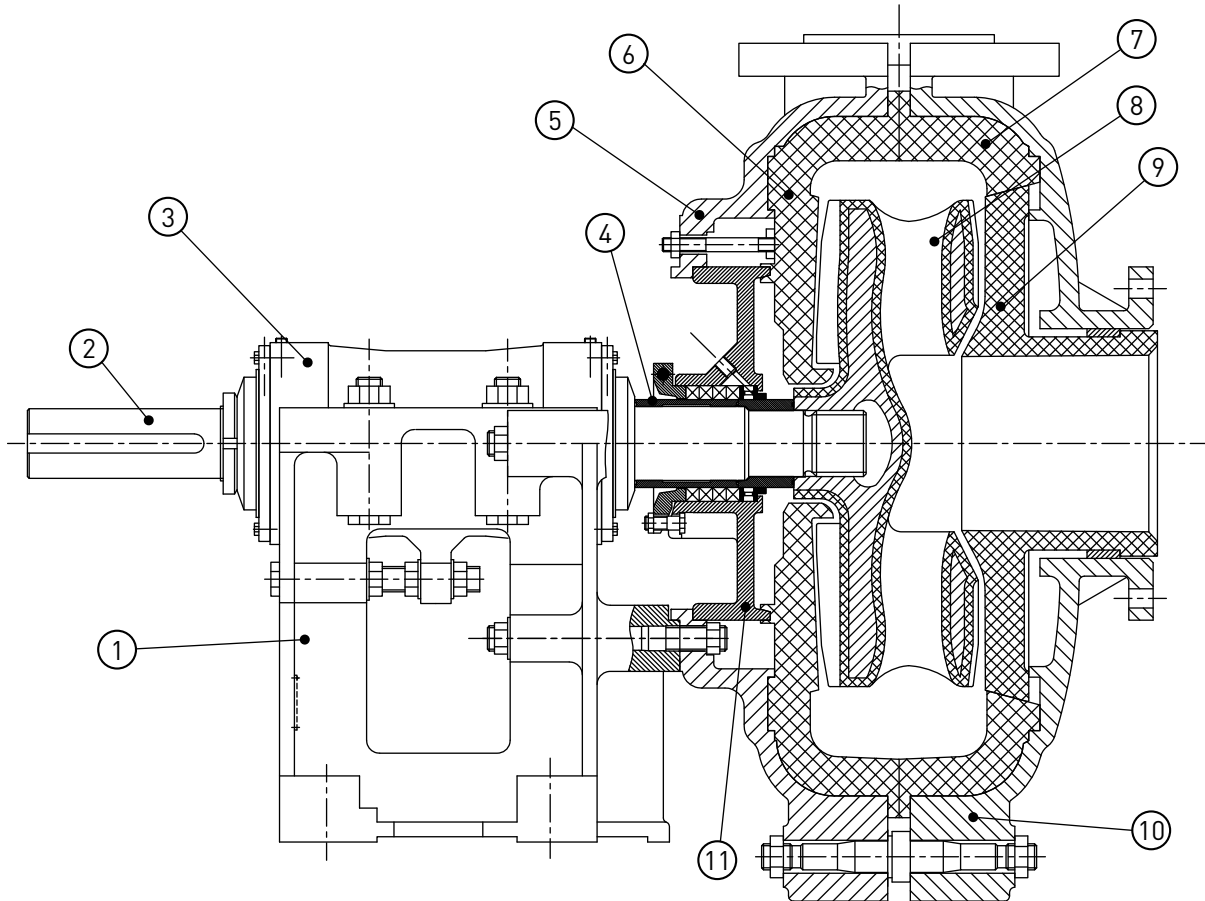

No.	Part Description	Material Specification
1	Base	Cast Iron
2	Shaft	4140 High Tensile Steel*
3	Bearing Assembly	Timkin (Cast Iron Body)
4	Shaft Sleeve	420 Stainless Steel
5	Pump Casing	Cast Iron
6	Frame Plate Liner Insert	Rubber
7	Cover Plate Liner	Rubber
8	Impeller	Rubber Coated High Tensile Steel
9	Throat Bush	Rubber
10	Cover Plate	Cast Iron
11	Stuffing Box	Cast Iron
12	Expeller	27% Chrome White Iron
13	Expeller Ring	Natural Rubber
	Bolts	Zinc Plated Steel
	O-rings	Nitrile Rubber
	Seals	Rubber

\* Other shaft material options are available.

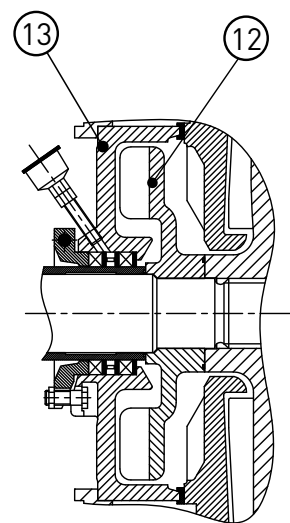

**METAL EXPELLER**  
**(RUBBER EXPELLER AVAILABLE)**



# MSP HEAVY DUTY SUMP PUMPS

---





# MSP

## HEAVY DUTY SUMP PUMPS

**Vertical, shaft driven centrifugal slurry pumps.** Rugged pumping solution for the transfer of slurries and large particles from sumps, pits, tanks and other fixed submersible applications.

### HEAVY DUTY SUMP PUMPING

MSP heavy duty sump pumps are vertical, shaft driven centrifugal slurry pumps designed for transferring abrasive and high density slurries from sumps, pits and other submersible sources.

Models are available in sizes ranging from 40mm to 250mm discharge and are capable of flow rates from 5 to 350 litres per second (79-5540 USGPM) at heads of up to 40 metres (130ft). The heavy duty design of the MSP pumps allows the passage of large particles with a diameter of up to 50mm.

Pumps will continue to operate even when the top inlet is not submerged, allowing the liquid level to be lowered to the bottom of the sump or pit. Suction extension pipes of up to 2 metres in length can be added to the bottom inlet of the pump to extend the pumping depth.

Designed as a fixed installation the MSP provides reliable pumping performance with minimal maintenance requirements and simple servicing.

### CANTILEVERED SHAFT

The standard MSP pumps feature a cantilevered shaft which is up to 2400mm long. The cantilevered shaft means that there is no shaft sealing requirement and the drive end bearings do not come into contact with any pumped product. This reduces the risk of bearing failure and extends the wear life of the pumps.

### HEAVY DUTY WET END

Wet end components are manufactured from high quality 27% chrome white iron or rubber coated steel for exceptional wear resistance and service life with minimal corrosion. The heavy duty design can pump high density and abrasive slurries and the large passages of the impeller allows the transfer of large particles without blockages in a wide range of mining, processing and heavy industrial applications.

Wet end stub shaft options are available to suit severe duty applications.

### COLUMN AND DISCHARGE PIPES

Column and discharge pipes are available in a range of materials to suit the requirements of operators. Standard options include mild steel and rubber lined mild steel. Composite options are available.

### VERSATILE DRIVE OPTIONS

MSP pumps can be directly driven using electric motors or belt driven with either set speed or variable speed operation.

**DEPON MSP HEAVY DUTY SUMP PUMP**



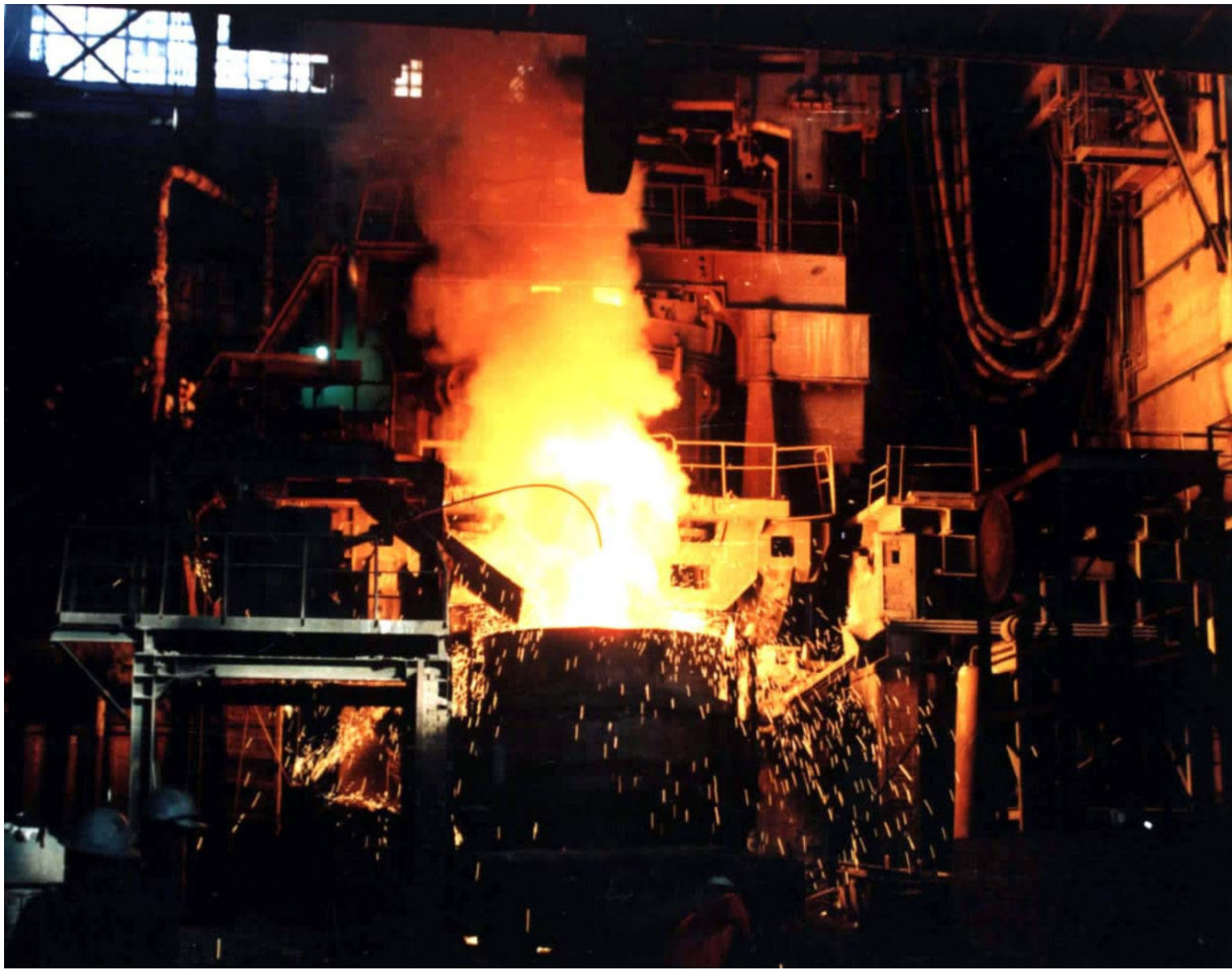

#### **REMOVABLE STRAINERS**

MSP pumps feature rubber or cast iron upper strainers and cast iron lower strainers to prevent blockages. The strainers are easily removed for servicing or replacement.

#### **“L” MODELS EXTENDED SHAFT**

The extended shaft “L” model features column bearings and shaft seal which further extends the pumping depth and enables the transfer of slurries from deeper sumps and pits.

#### **“L” MODEL WITH EXTENDED SHAFT AND SHAFT SEAL**



The MSP Heavy Duty Sump Pumps are capable of providing reliable and efficient performance for the transfer of abrasive and high density slurries from sumps, pits and tanks in a wide range of mining, processing and heavy industrial applications.

# TECHNICAL DATA

## SELECTION CHART

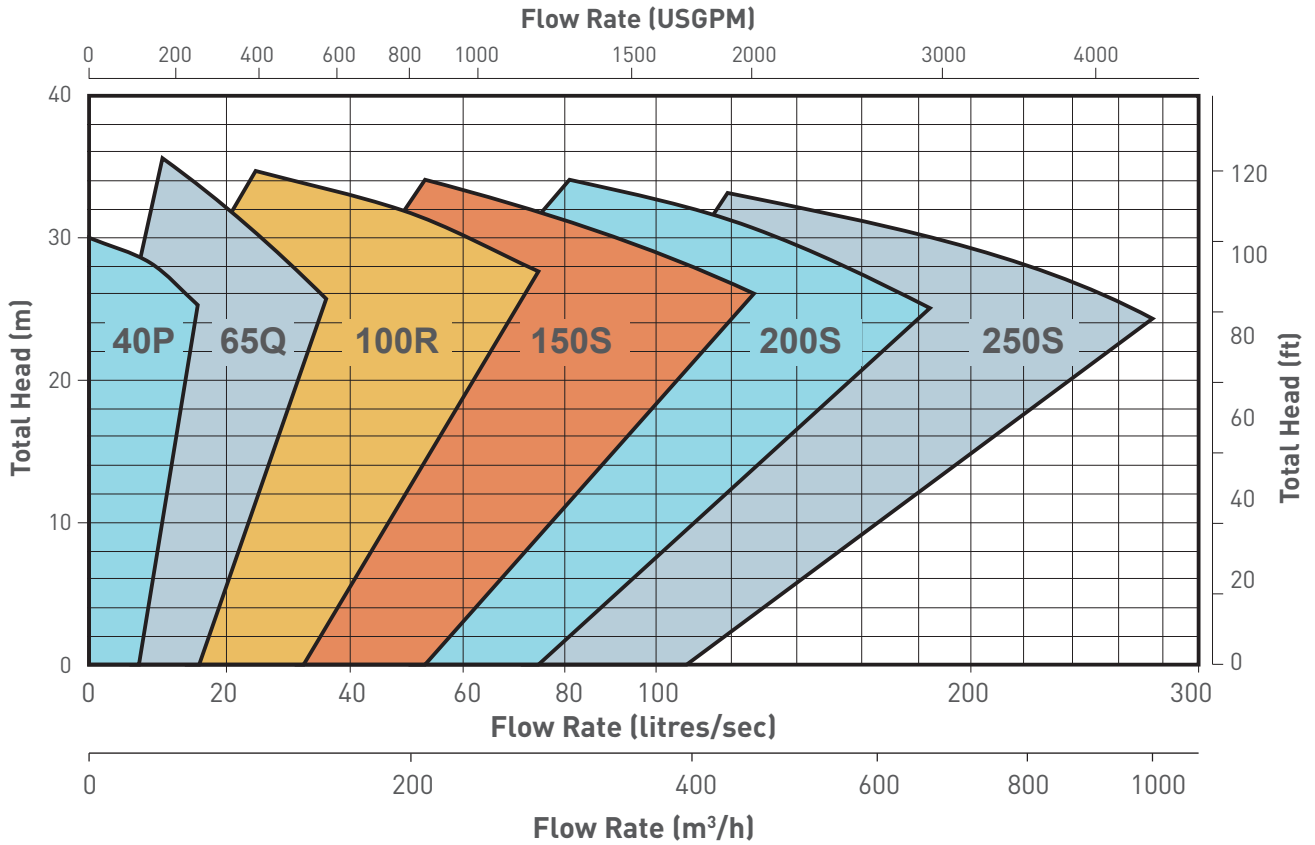

## MATERIALS OF CONSTRUCTION



CANTILEVERED SHAFT

EXTENDED SHAFT

Description	Standard Material	Material Options
Shaft	4140 Mild Steel	Available on Request <sup>1</sup>
Bearing Housing	Cast Iron	
Column	Mild Steel	
Upper Strainer	Rubber	Cast Iron
Lower Strainer	Cast Iron	
Back Liner	27% Chrome White Iron	
Pump Casing	27% Chrome White Iron	Rubber Lined White Iron
Impeller	27% Chrome White Iron	Rubber
Discharge Pipe	Mild Steel	Rubber Lined Mild Steel / Composite
Adaptor Plate	Mild Steel	

<sup>1</sup> installations. Contact us to discuss the availability of material options.

# TECHNICAL DATA

## DIMENSIONS

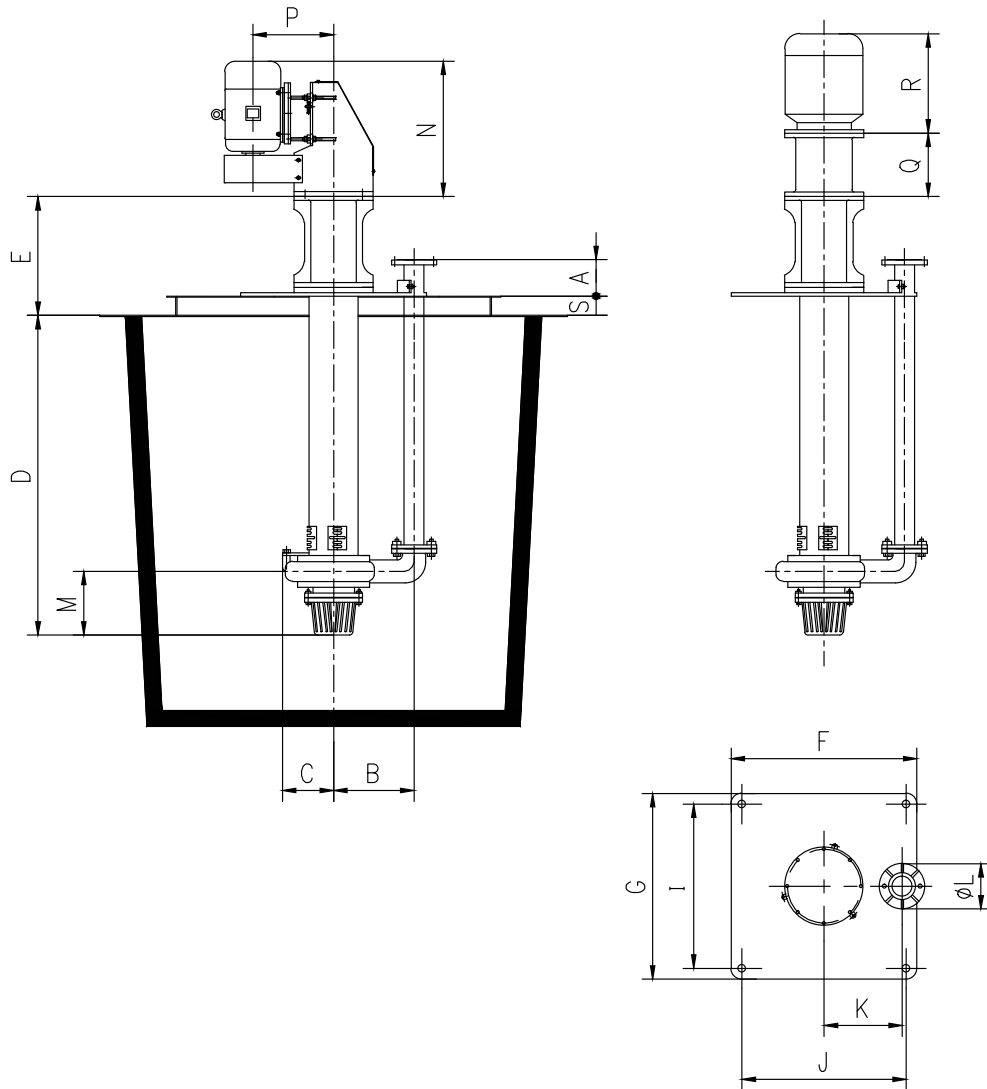

Model	Length (mm)																	
	A	B	C	D	E	F	G	H	J	K	L	M	N	P	Q	R	S	
40P	137	285	153	900*	380	500	500	450	450	205	127	174	733	675	248	629	280	
40PR	140	265	175	1200	380	500	500	450	450	205	127	174	733	675	248	629	280	
65Q	227	399	231	900	492	680	680	620	620	285	178	265	898	794	290	681	350	
65QR	230	380	260	1200*	498	680	680	620	620	285	178	265	898	794	290	681	350	
100R	260	538	317	1200	662	1000	870	800	930	400	229	393	1141	1020	416	960	350	
100RR	266	535	332	1500*	668	1000	870	800	930	400	229	393	1141	1020	416	960	350	
150S	390	670	365	1500	875	1100	1100	1030	1030	500	280	475	1311	1200	476	1011	350	
150SR	395	670	400	1800*	883	1100	1100	1030	1030	500	280	475	1311	1200	476	1011	350	
200S	450	805	440	1800	878	1300	1200	1100	1200	600	343	550	1313	1300	476	1011	350	
200SR	450	805	440	2100*	878	1300	1200	1100	1200	600	343	550	1313	1300	476	1011	350	
250S	500	930	470	1800	1000	1750	1450	1350	1650	700	406	685	1572	1750	561	1246	400	
250SR	500	930	470	2100*	1000	1750	1450	1350	1650	700	406	685	1572	1750	561	1246	400	

\* Standard length.

# MSP 40PR

## RUBBER LINER AND IMPELLER

### PUMP SPECIFICATIONS

Outlet Dia. (mm)	Bearing Frame	Max Power (kW)	Max Particle Size (mm)	Pumping Depth (mm)	No. of Vanes	Impeller Material	Impeller Dia. (mm)	Wear Liner Material
40	P	15	12	900* 1200	5	Rubber Lined High Tensile Steel	188 - 195	Rubber

\* Standard pumping depth.

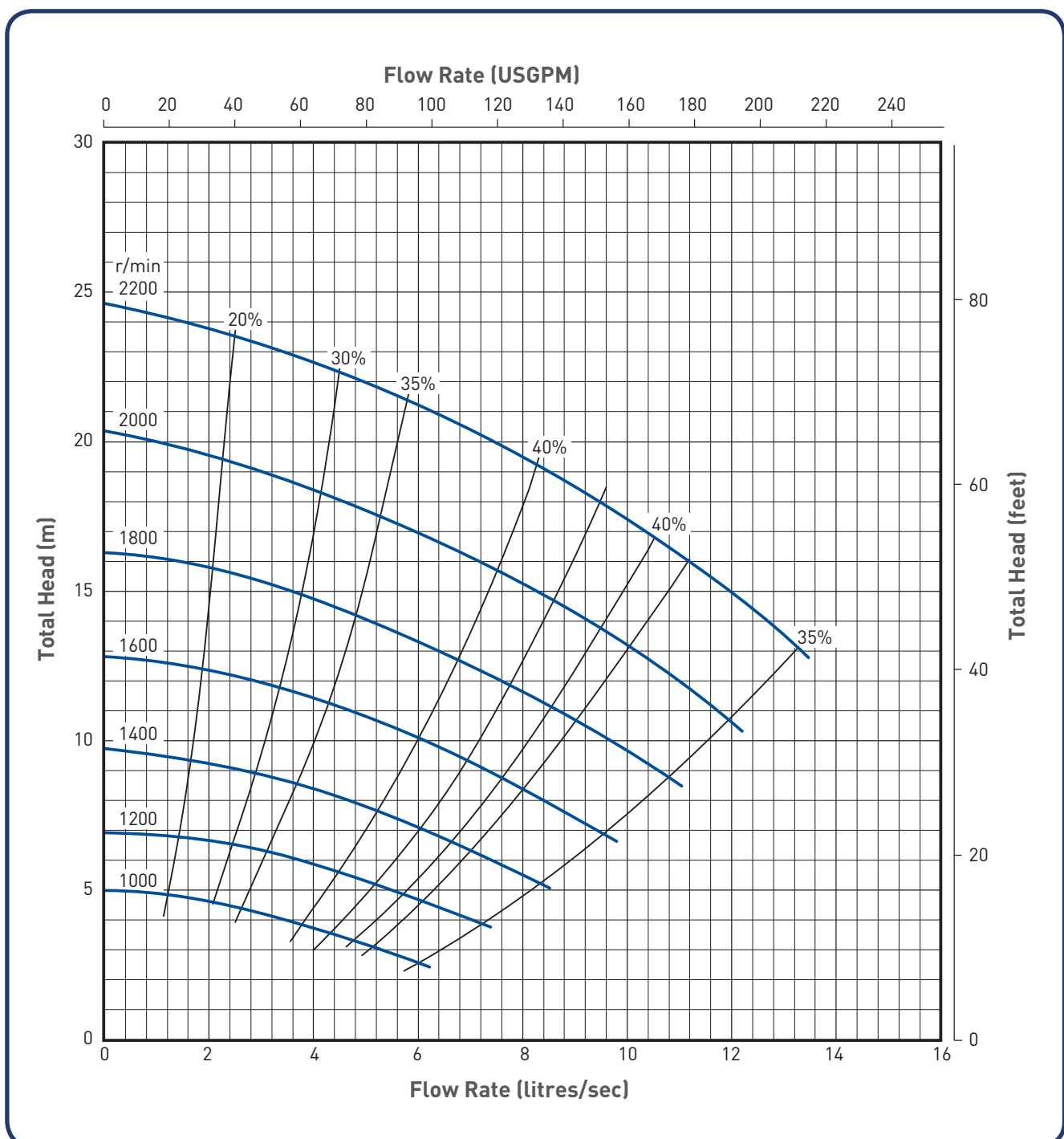

# MSP 40P

## METAL LINER AND IMPELLER

### PUMP SPECIFICATIONS

Outlet Dia. (mm)	Bearing Frame	Max Power (kW)	Max Particle Size (mm)	Pumping Depth (mm)	No. of Vanes	Impeller Material	Impeller Dia. (mm)	Wear Liner Material
40	P	15	12	900* 1200	5	27% Chrome White Iron	188	27% Chrome White Iron

\* Standard pumping depth.

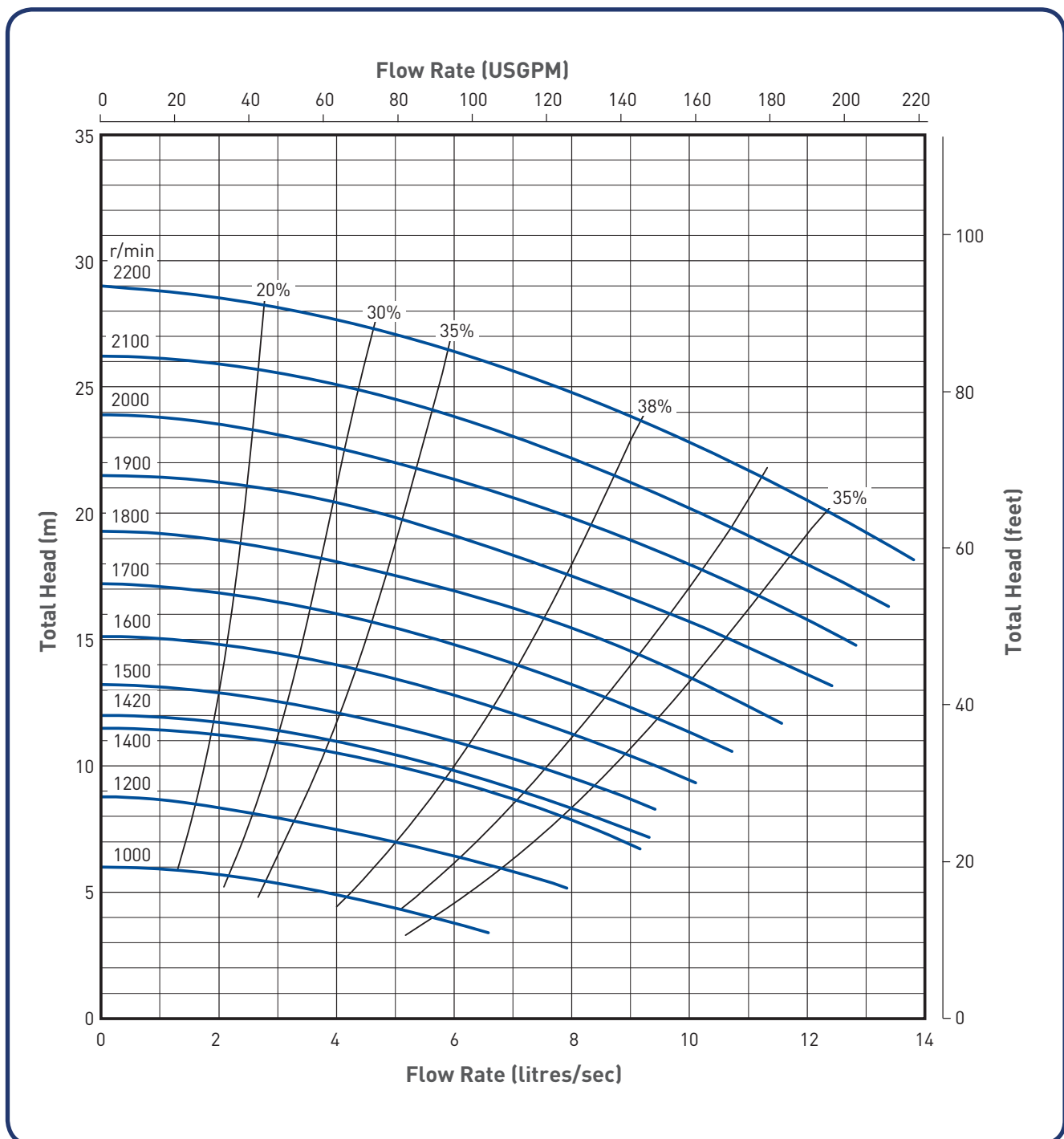

# MSP 65QR

## RUBBER LINER AND IMPELLER

### PUMP SPECIFICATIONS

Outlet Dia. (mm)	Bearing Frame	Max Power (kW)	Max Particle Size (mm)	Pumping Depth (mm)	No. of Vanes	Impeller Material	Impeller Dia. (mm)	Wear Liner Material
65	Q	30	15	900 1200* 1500	5	Rubber Lined High Tensile Steel	280 - 290	Rubber

\* Standard pumping depth.

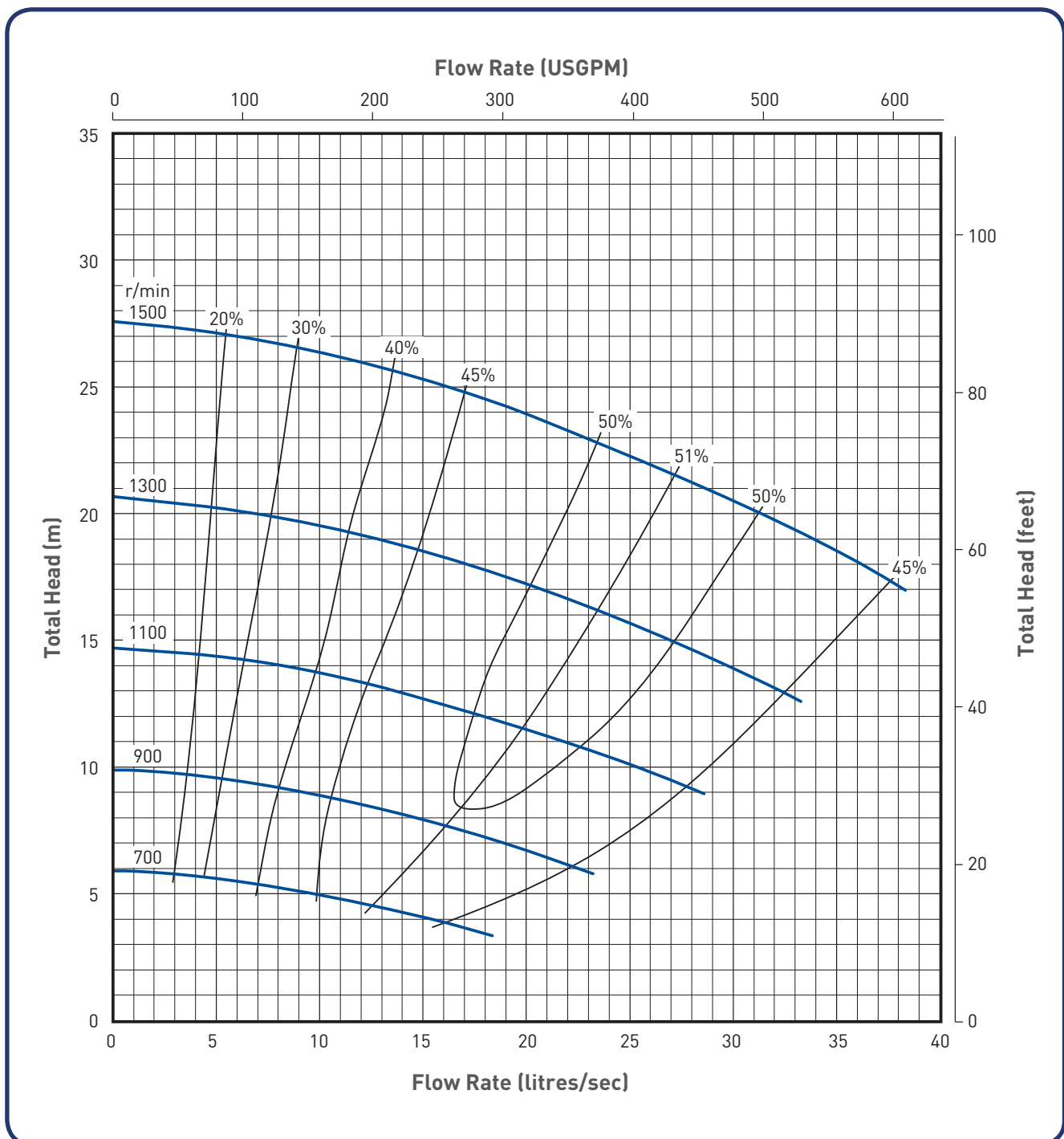

# MSP 65Q

## METAL LINER AND IMPELLER

### PUMP SPECIFICATIONS

Outlet Dia. (mm)	Bearing Frame	Max Power (kW)	Max Particle Size (mm)	Pumping Depth (mm)	No. of Vanes	Impeller Material	Impeller Dia. (mm)	Wear Liner Material
65	Q	30	15	900 1200* 1500	5	27% Chrome White Iron	280	27% Chrome White Iron

\* Standard pumping depth.

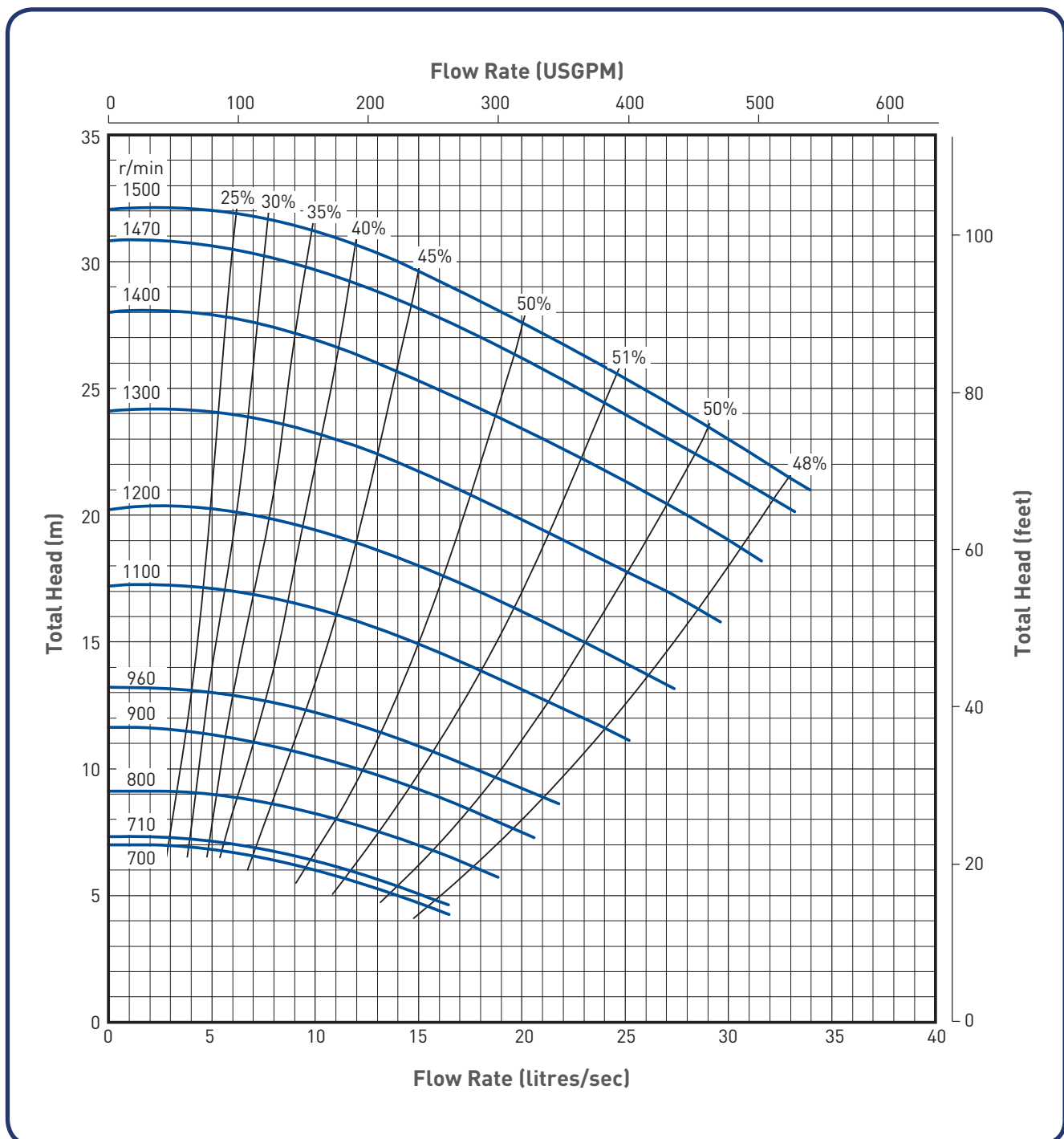

# MSP 100RR

## RUBBER LINER AND IMPELLER

### PUMP SPECIFICATIONS

Outlet Dia. (mm)	Bearing Frame	Max Power (kW)	Max Particle Size (mm)	Pumping Depth (mm)	No. of Vanes	Impeller Material	Impeller Dia. (mm)	Wear Liner Material
100	R	75	40	1200 1500* 2100	5	Rubber Lined High Tensile Steel	370	Rubber

\* Standard pumping depth.

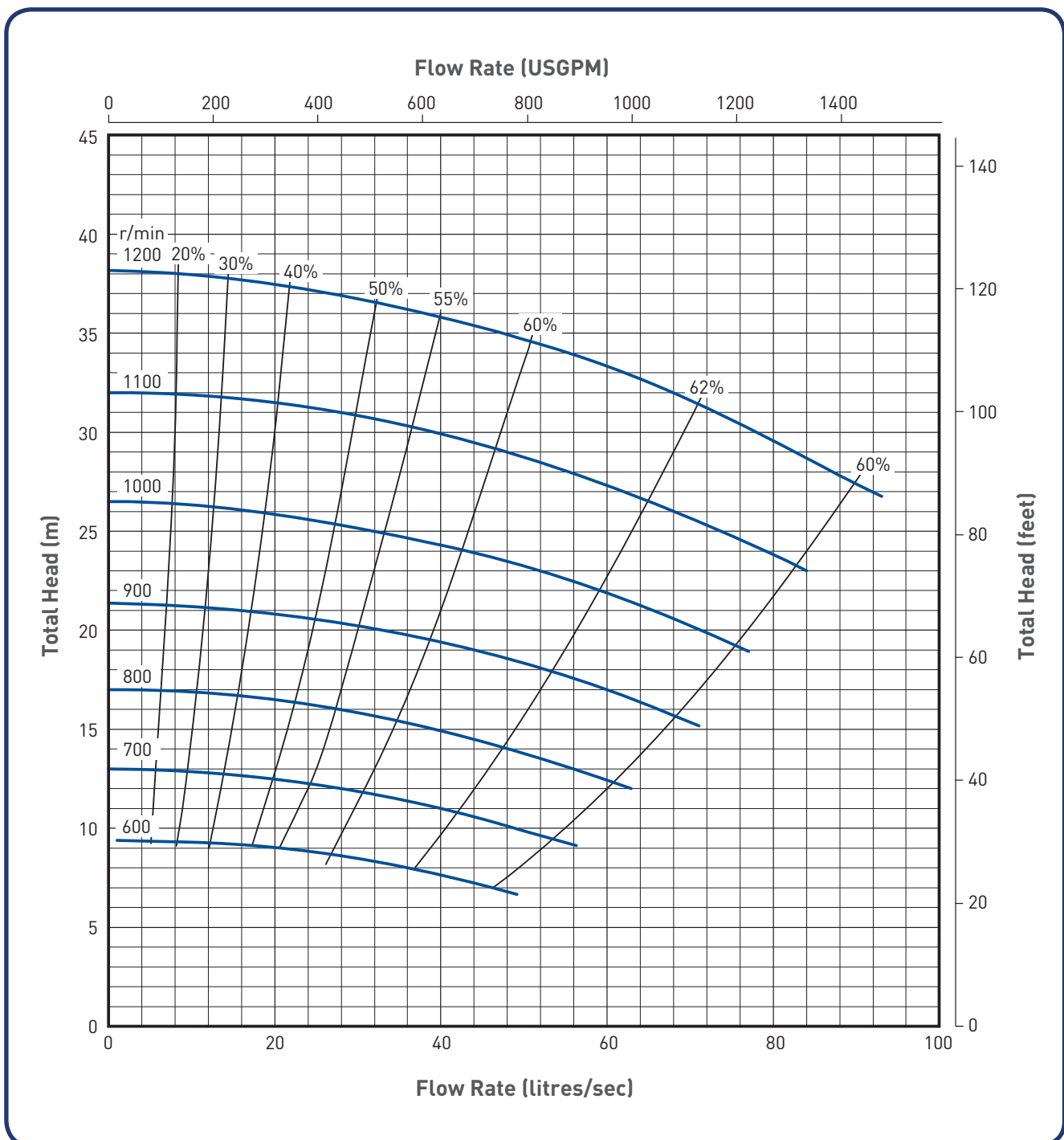

# MSP 100R

## METAL LINER AND IMPELLER

### PUMP SPECIFICATIONS

Outlet Dia. (mm)	Bearing Frame	Max Power (kW)	Max Particle Size (mm)	Pumping Depth (mm)	No. of Vanes	Impeller Material	Impeller Dia. (mm)	Wear Liner Material
100	R	75	32	1200 1500* 2100	5	27% Chrome White Iron	370	27% Chrome White Iron

\* Standard pumping depth.

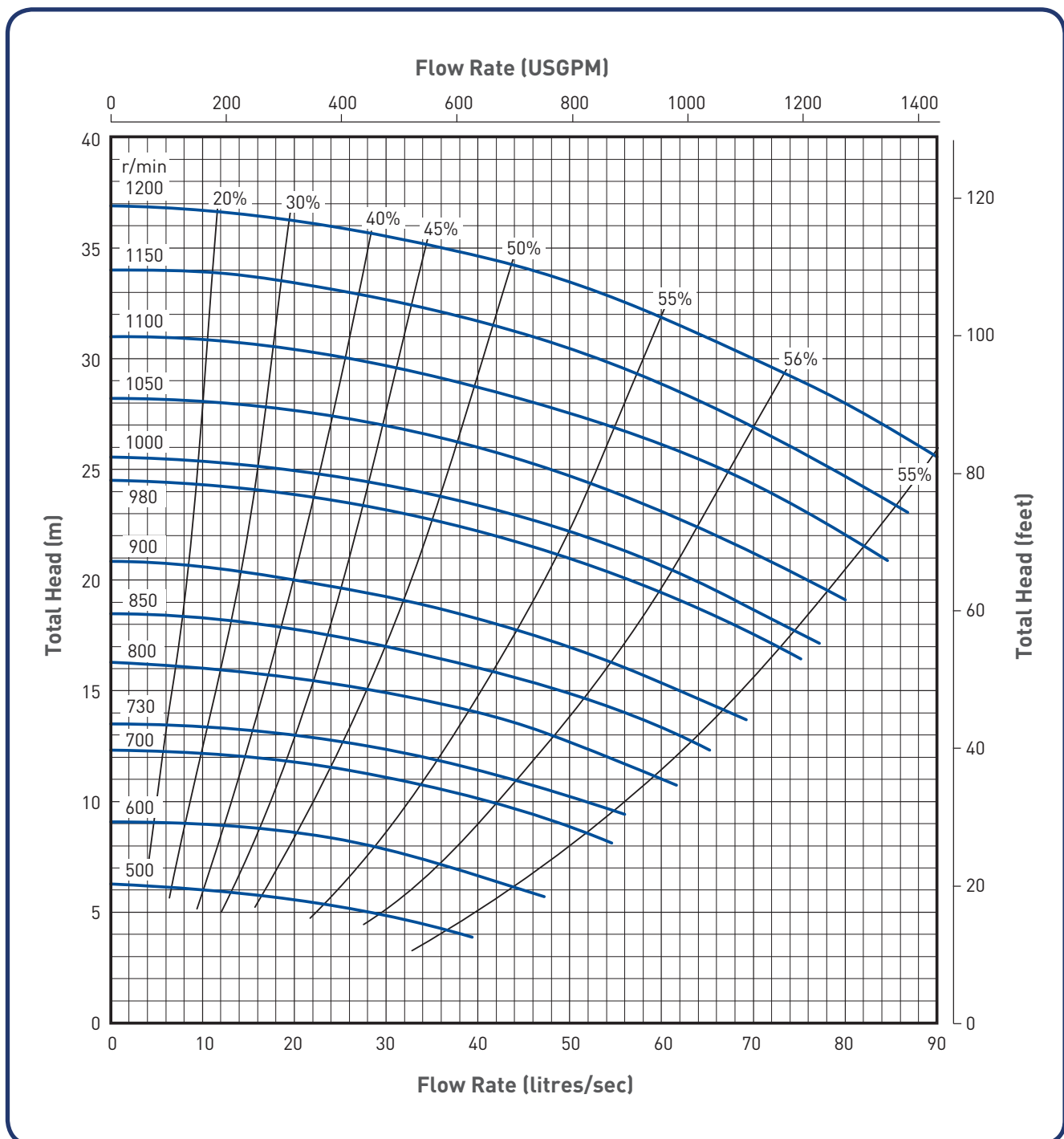

# MSP 150SR

## RUBBER LINER AND IMPELLER

### PUMP SPECIFICATIONS

Outlet Dia. (mm)	Bearing Frame	Max Power (kW)	Max Particle Size (mm)	Pumping Depth (mm)	No. of Vanes	Impeller Material	Impeller Dia. (mm)	Wear Liner Material
150	S	110	45	1500 1800* 2100	5	Rubber Lined High Tensile Steel	450	Rubber

\* Standard pumping depth.

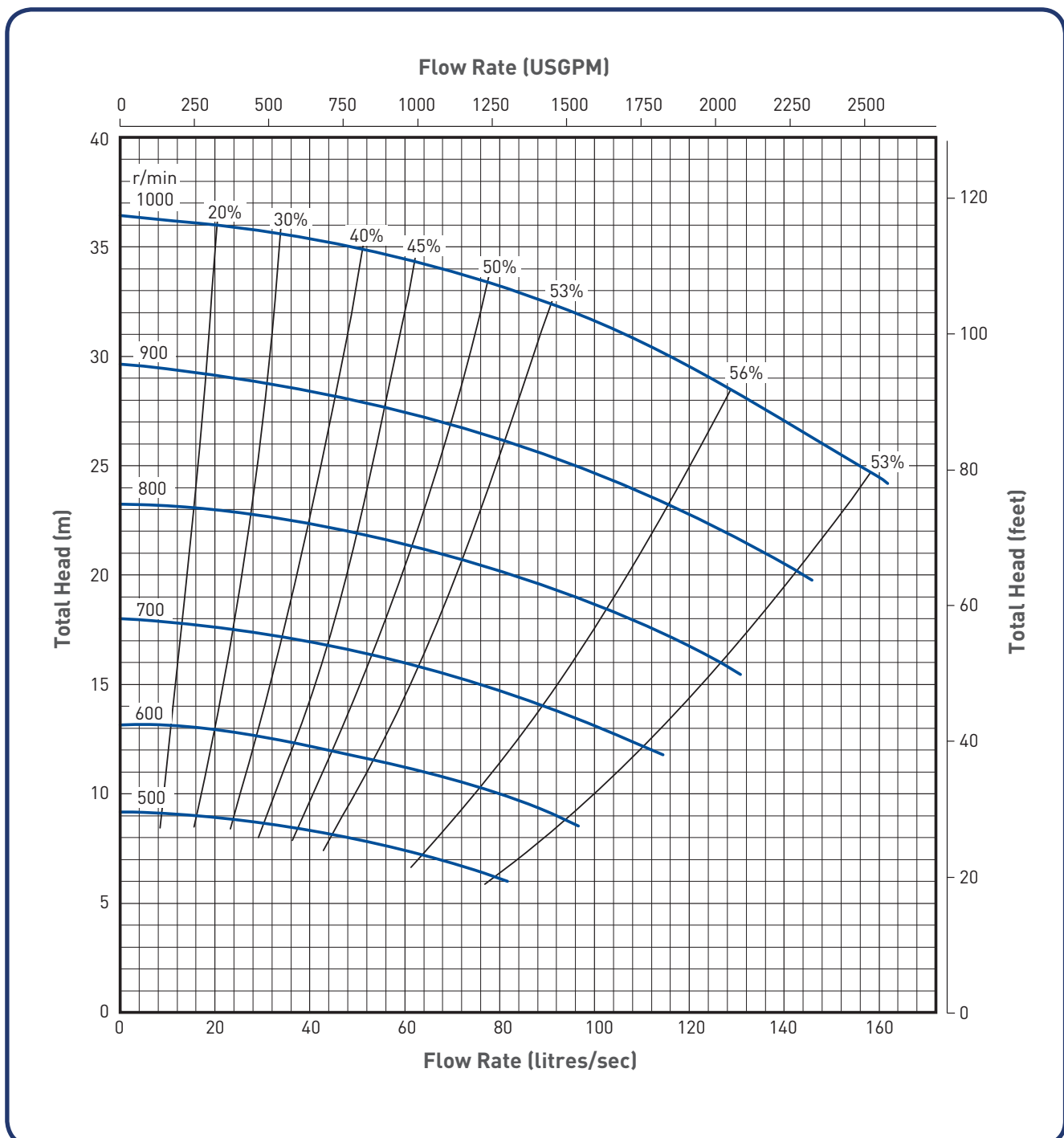

# MSP 150S

## METAL LINER AND IMPELLER

### PUMP SPECIFICATIONS

Outlet Dia. (mm)	Bearing Frame	Max Power (kW)	Max Particle Size (mm)	Pumping Depth (mm)	No. of Vanes	Impeller Material	Impeller Dia. (mm)	Wear Liner Material
150	S	110	45	1500 1800* 2100	5	27% Chrome White Iron	450	27% Chrome White Iron

\* Standard pumping depth.

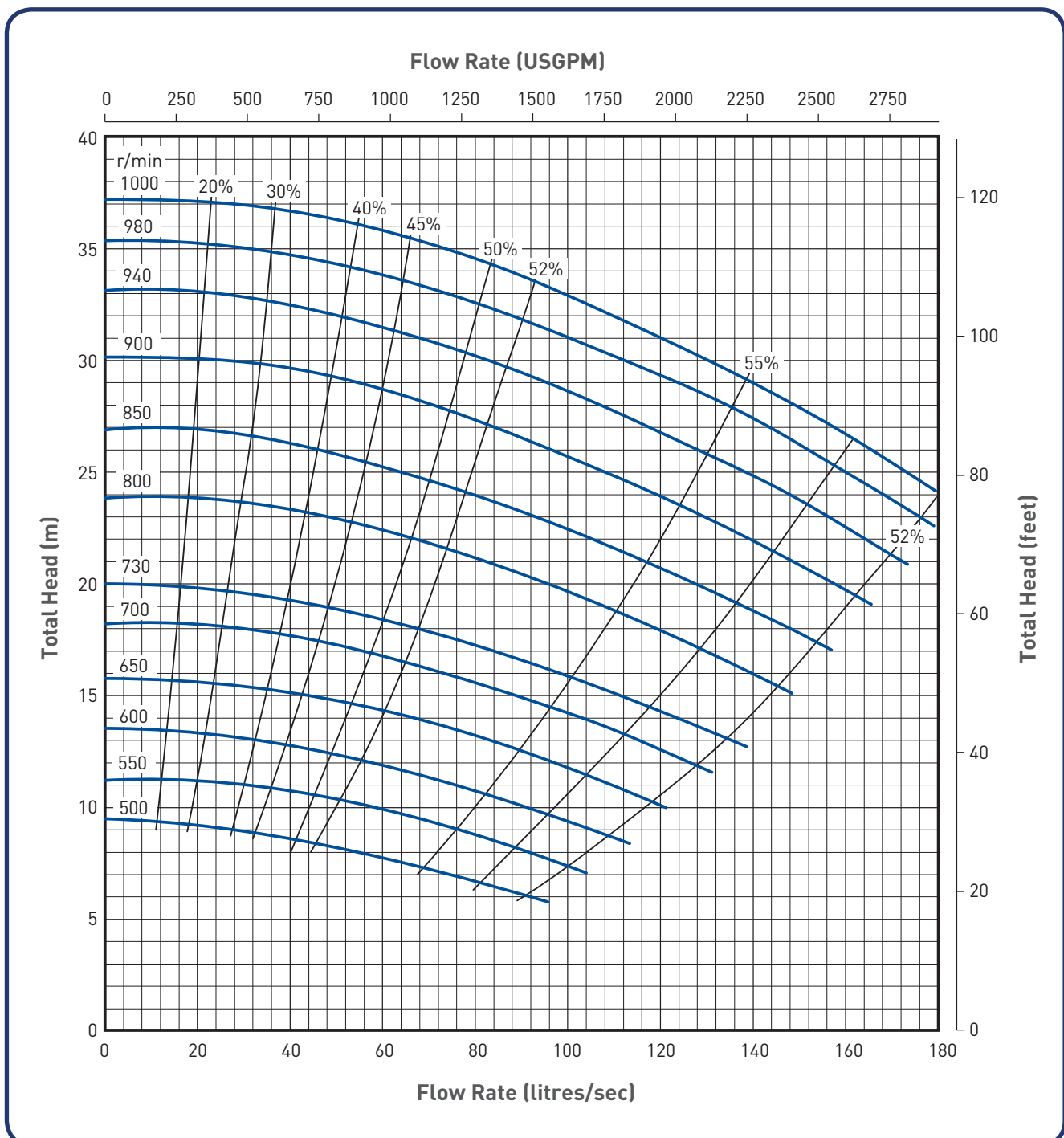



SS  
ELECTRO-SUBMERSIBLE  
SLURRY PUMPS

---



# SS

## ELECTRO-SUBMERSIBLE SLURRY PUMPS

**Durable, electro-submersible slurry pumps.** Versatile and rugged solution for the transfer of abrasive and high density slurries in mining, civil construction, industry and other heavy duty applications.

### VERSATILE HEAVY DUTY SOLUTION

Depon SS series are a heavy duty, electro-submersible slurry pumps designed to handle a wide range of slurries and abrasive particles in submersible applications in mining and industry.

SS pumps feature a rugged construction using the highest quality materials to ensure reliable performance and excellent service life. The high quality electric motors incorporate multiple protection features to detect the ingress of water or excessive temperatures to shut off the pump and prevent damage.

Pumps are available in 72 different models in sizes ranging from 80mm to 400mm (3.15 - 16 inches) discharge and are capable of flow rates from 23 to 2400 cubic metres per hour (100-10560USGPM) and heads up to 64 metres (210ft). Pumps can pass solids up to 60mm (2.4 inches) in diameter enabling them to transfer dense slurries with large abrasive particles.

### LARGE CUT WATER CLEARANCE

The pump casing features a large cut water clearance which allows the easy passage of large solids and reduces wear and erosion to improve service life and prevent loss of efficiency.

### INTEGRAL AGITATOR

The 27% chrome white iron agitator assists in the pumping of slurries by breaking up large particles and agitating high concentrations of solids.

### HEAVY DUTY CONSTRUCTION

The pump casing, impeller, backplate and agitator are manufactured from high quality 27% chrome white iron. This extremely tough construction material can withstand continuous use in heavy duty applications and allows the SS pumps to transfer abrasive and dense slurries with minimal wear. The pumps feature a replaceable backplate allowing for simple servicing and easy replacement of worn components.

### F CLASS MOTOR INSULATION

F class motor insulation is used to ensure reliable operation in heavy duty applications in temperatures up to +40°C. In applications where higher temperatures are expected, H class motor insulation can be used to allow operating temperatures up to +70°C.

### SUPPORT FRAME AND STRAINER

A heavy duty mild steel frame with round base and strainer provide excellent stability and durability whilst preventing blockages.

### DEPON SS280-40-75 SUBMERSIBLE SLURRY PUMP





#### **DOUBLE MECHANICAL SEAL**

A double mechanical seal provides excellent shaft sealing between the electric motor and wet end. The seals are oil bath lubricated and feature carbon/ceramic seal faces in the wet end and tungsten ceramic faces in the drive end to provide excellent durability and service life across a wide range of duties and applications.

#### **OIL CHAMBER LEAKAGE PROBE**

The oil chamber incorporates a water leakage probe which detects when the water-to-oil ratio is too high and automatically shuts down the motor to prevent damage.

#### **MOTOR FLOAT SWITCH**

A float switch is located in the bottom of the motor to detect the ingress of water and shut down the motor to prevent damage due to shorting out.

#### **MOTOR TEMPERATURE SENSORS**

Temperature sensors are located in the motor stator to detect excessive temperatures and can shut down the motor to prevent damage due to overheating.

#### **THRUST BEARING SENSORS**

Temperature and moisture sensors are located in the motor thrust bearings to detect excessive temperatures and the ingress of water and shut down the motor to prevent bearing failure.

#### **OPTIONAL EXTERNAL COOLING**

Cooling jackets can be provided with external water supply in high temperature applications to keep motor temperature down and prevent excessive stator and bearing damage.

SS Submersible Slurry Pumps are available in 72 different models in sizes ranging from 80mm to 400 mm (3.15-16 inches) discharge and are capable of flow rates up to 2400 cubic metres per hour (100-10560UGPM).

# PUMP PERFORMANCE SELECTION CHART (25-100m<sup>3</sup>/hr)

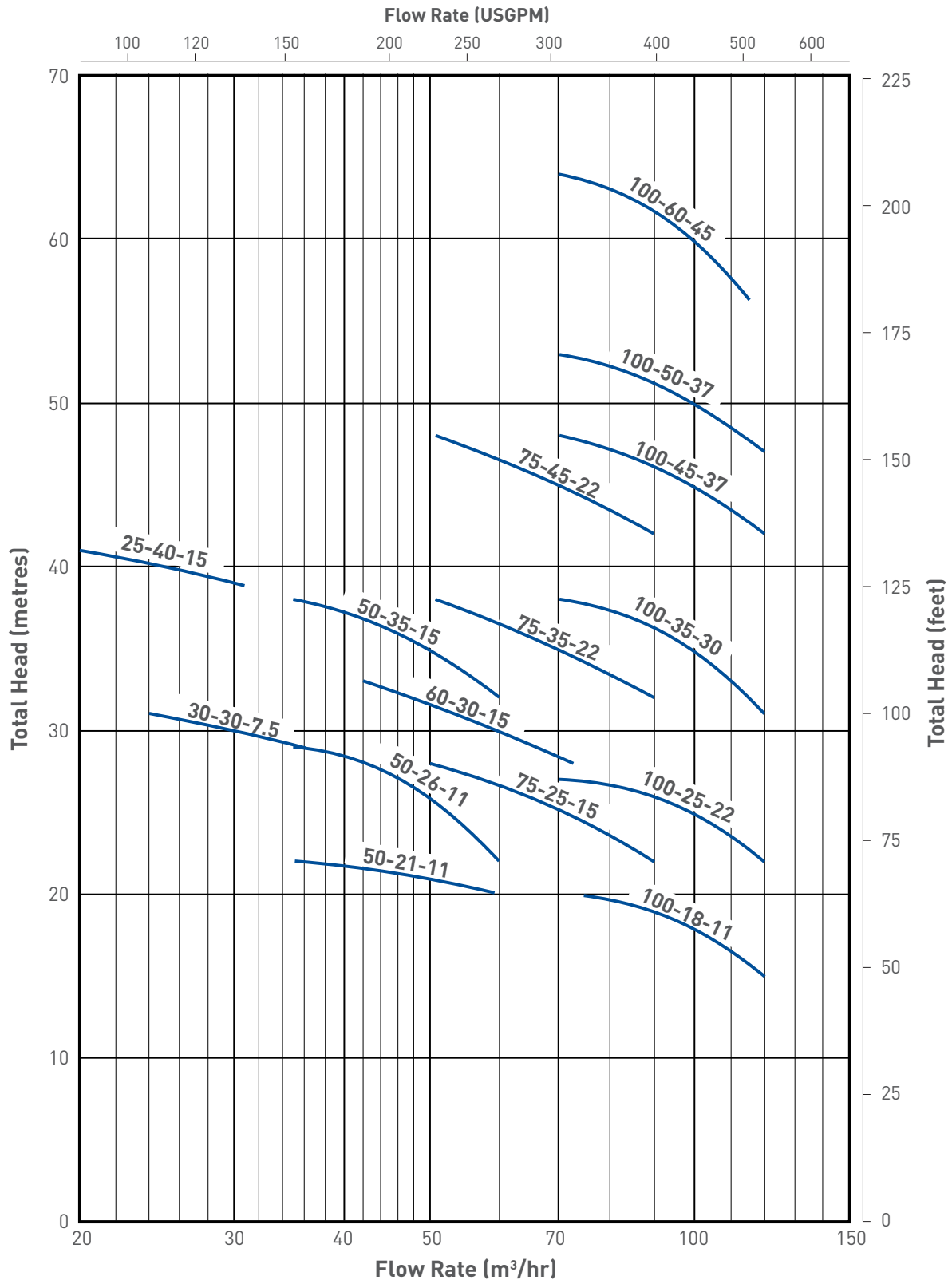

Performance curve is for clean, cold water only. Contact us to discuss pump selections for specific applications.

# PUMP PERFORMANCE SELECTION CHART (150-800m<sup>3</sup>/hr)

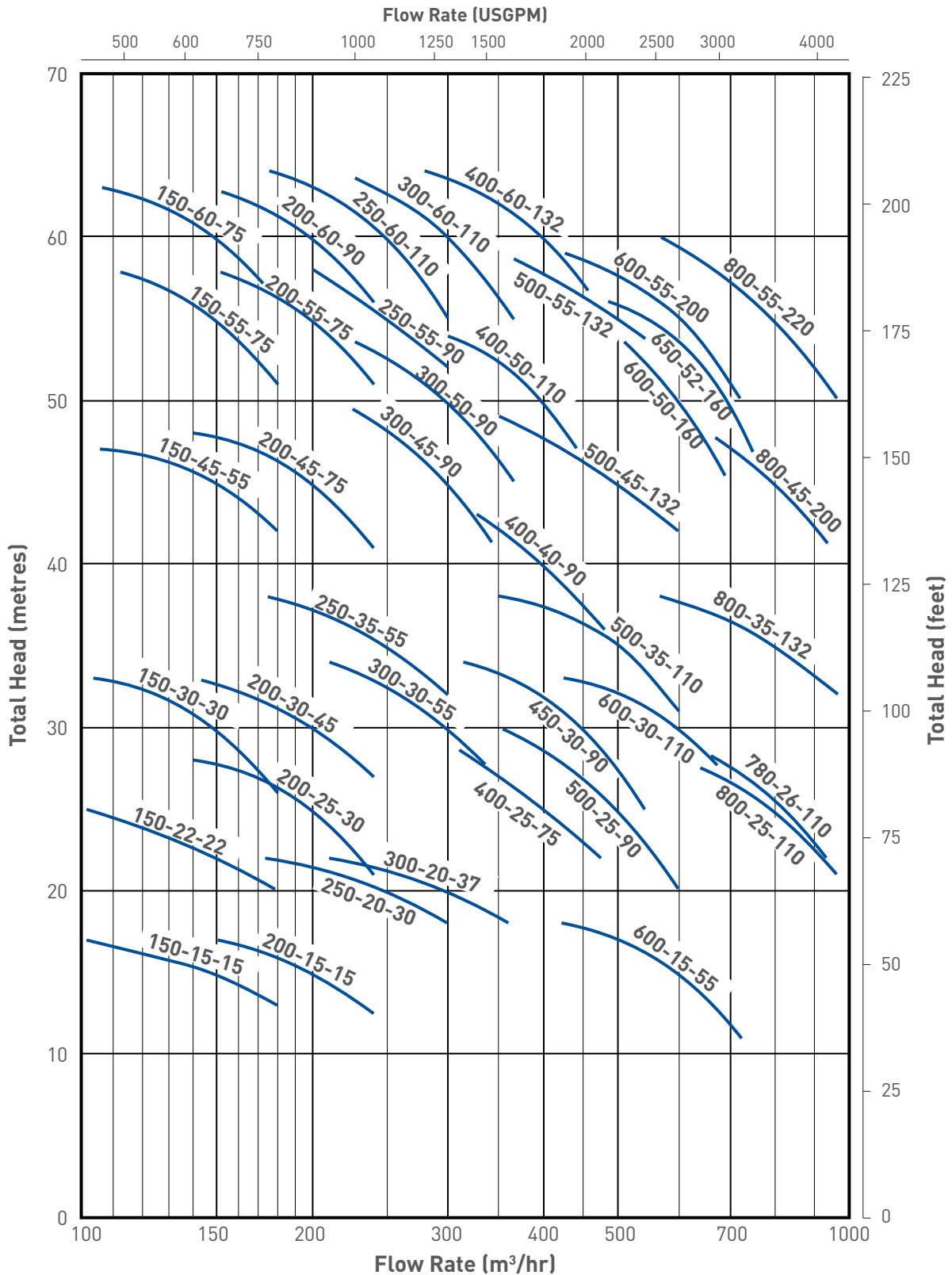

Performance curve is for clean, cold water only. Contact us to discuss pump selections for specific applications.

# PUMP PERFORMANCE SELECTION CHART (1000-2000m<sup>3</sup>/hr)

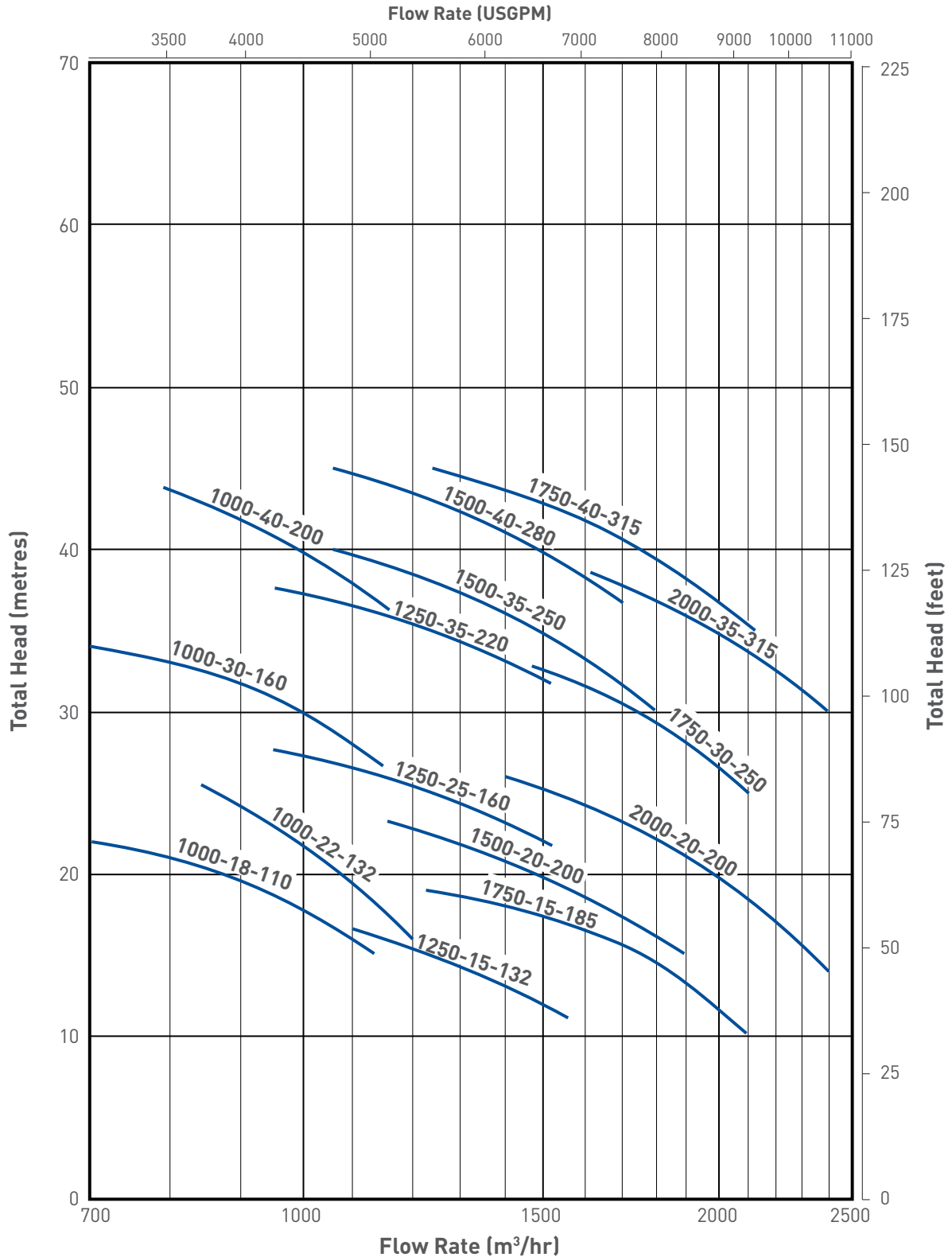

Performance curve is for clean, cold water only. Contact us to discuss pump selections for specific applications.



# TECHNICAL DATA (CONTINUED)

Model	Outlet Dia. (inch)	Capacity (USGPM)	Head (ft)	Motor Power (hp)	Speed (r/min)	Efficiency (%)	Max. Dia. of Solids (inch)
SS30-30-7.5	3.15	106	100	10	1460	43	0.5
		132	97				
		158	93				
SS50-21-11	4	154	71	15	1460	48	0.8
		220	68				
		264	64				
SS100-18-11	4	308	64	15	1460	55	0.5
		440	58				
		528	48				
SS25-40-15	3.15	79	132	20	1460	35	0.8
		110	129				
		132	126				
SS50-35-15	4	154	122	20	1460	47	0.5
		220	113				
		264	103				
SS60-30-15	4	185	106	20	1460	50	0.5
		264	97				
		317	87				
SS75-25-15	4	229	90	20	1460	51	0.5
		330	80				
		396	71				
SS150-15-15	6	462	55	20	1460	56	0.5
		660	48				
		792	42				
SS50-26-22	3.15	154	93	15	1460	48	0.8
		220	84				
		264	77				
SS75-35-22	4	229	122	30	980	48	0.5
		330	113				
		396	103				
SS75-45-22	4	229	154	30	980	48	0.5
		330	145				
		396	135				
SS100-25-22	4	308	87	30	980	55	0.6
		440	80				
		528	71				
SS150-22-22	6	462	80	30	980	60	1.3
		660	71				
		792	64				
SS200-15-22	6	616	55	30	980	60	1.8
		880	48				
		1056	43				
SS100-35-30	4	308	122	40	980	50	0.8
		440	113				
		528	100				
SS150-30-30	6	462	106	40	980	50	0.8
		660	97				
		792	84				

# SS

## TECHNICAL DATA (CONTINUED)

Model	Outlet Dia. (inch)	Capacity (USGPM)	Head (ft)	Motor Power (hp)	Speed (r/min)	Efficiency (%)	Max. Dia. of Solids (inch)
SS200-25-30	6	616	90	40	980	51	1.0
		880	80				
		1056	68				
SS250-20-30	6	770	74	40	980	60	1.0
		1100	64				
		1320	58				
SS100-45-37	4	308	154	50	980	43	0.8
		440	145				
		528	135				
SS100-50-37	4	308	171	50	980	43	0.5
		440	161				
		528	151				
SS300-20-37	6	1056	71	50	980	58	1.1
		1320	64				
		1584	55				
SS100-60-45	4	308	206	60	980	43	0.5
		440	193				
		528	177				
SS200-30-45	6	616	106	60	980	53	1.0
		880	97				
		1056	87				
SS150-45-55	6	462	151	75	980	50	0.8
		660	145				
		792	135				
SS250-35-55	6	770	122	75	980	53	1.4
		1100	113				
		1320	106				
SS300-30-55	6	924	109	75	980	55	1.4
		1320	97				
		1584	84				
SS600-15-55	10	1848	58	75	980	62	1.3
		2640	48				
		3168	35				
SS150-55-75	6	462	187	100	980	48	0.6
		660	177				
		792	164				
SS150-60-75	6	462	203	100	980	48	0.6
		660	193				
		792	180				
SS200-45-75	6	616	154	100	980	52	0.8
		880	145				
		1056	132				
SS200-55-75	6	616	187	100	980	50	0.8
		880	177				
		1056	164				
SS350-35-75	8	1078	251	100	980	60	1.1
		1540	241				
		1848	228				



# TECHNICAL DATA (CONTINUED)

Model	Outlet Dia. (inch)	Capacity (USGPM)	Head (ft)	Motor Power (hp)	Speed (r/min)	Efficiency (%)	Max. Dia. of Solids (inch)
SS400-25-75	8	1232	93	100	980	62	1.1
		1760	80				
		2112	74				
SS200-60-90	6	616	203	125	980	50	0.6
		880	193				
		1056	183				
SS250-55-90	6	748	187	125	980	50	0.6
		1100	177				
		1320	167				
SS300-45-90	6	924	161	125	980	52	1.0
		1320	145				
		1584	126				
SS300-50-90	6	924	174	125	980	52	1.0
		1320	161				
		1584	145				
SS400-40-90	8	1232	142	125	980	53	1.0
		1760	129				
		2112	116				
SS500-25-90	8	1540	97	125	980	65	1.0
		2200	80				
		2640	64				
SS450-30-90	8	1386	109	125	980	64	1.0
		1980	97				
		2376	80				
SS250-60-110	6	770	206	150	980	54	0.8
		1100	193				
		1320	177				
SS300-60-110	6	924	206	150	980	55	0.8
		1320	193				
		1584	180				
SS400-50-110	8	1232	174	150	980	56	1.1
		1760	161				
		2112	145				
SS500-35-110	8	1540	122	150	980	61	1.3
		2200	113				
		2640	100				
SS600-30-110	10	1848	106	150	980	64	1.4
		2640	97				
		3168	84				
SS800-25-110	12	2464	90	150	980	66	2.0
		3520	80				
		4224	68				
SS1000-18-110	12	3080	71	150	980	68	2.0
		4400	58				
		5280	42				
SS780-26-110	12	2398	93	150	980	68	2.0
		3432	84				
		4114	71				

# SS

## TECHNICAL DATA (CONTINUED)

Model	Outlet Dia. (inch)	Capacity (USGPM)	Head (ft)	Motor Power (hp)	Speed (r/min)	Efficiency (%)	Max. Dia. of Solids (inch)
SS400-60-132	8	1232	206	175	980	68	1.1
		1760	193				
		2112	177				
SS500-45-132	8	1540	158	175	980	67	1.1
		2200	145				
		2640	135				
SS500-55-132	8	1540	190	175	980	70	1.1
		2200	177				
		2640	167				
SS800-35-132	12	2464	122	175	980	70	1.7
		3520	113				
		4224	103				
SS1000-22-132	12	3080	87	175	980	71	2.0
		4400	71				
		5280	55				
SS1250-15-132	12	3850	58	175	980	70	2.2
		5500	48				
		6600	39				
SS600-50-160	8	1848	180	215	980	65	1.1
		2640	161				
		3168	138				
SS650-52-160	8	2002	180	215	980	65	1.1
		2860	167				
		3432	142				
SS1250-25-160	14	3850	90	215	980	70	2.2
		5500	80				
		6600	71				
SS1000-30-160	12	3080	109	215	980	70	2.9
		4400	97				
		5280	80				
SS1750-15-185	14	5390	61	250	980	70	2.2
		7700	48				
		9240	32				
SS600-55-200	10	1848	190	265	980	62	1.1
		2640	177				
		3168	161				
SS800-45-200	12	2464	158	265	980	66	1.7
		3520	145				
		4224	129				
SS1000-40-200	12	3080	145	265	980	70	1.7
		4400	129				
		5280	113				
SS1500-20-200	14	4620	77	265	980	71	2.2
		6600	64				
		7920	48				
SS2000-20-200	16	6160	80	265	980	72	2.2
		8800	84				
		10560	45				

# SS

## TECHNICAL DATA (CONTINUED)

Model	Outlet Dia. (inch)	Capacity (USGPM)	Head (ft)	Motor Power (hp)	Speed (r/min)	Efficiency (%)	Max. Dia. of Solids (inch)
SS800-55-220	12	2464	193	300	980	66	1.5
		3520	177				
		4224	161				
SS1250-35-220	14	3850	126	300	980	70	1.8
		5500	113				
		6600	97				
SS1000-50-250	12	3080	177	330	980	68	1.8
		4400	161				
		5280	145				
SS1500-35-250	14	4620	129	330	980	72	2.0
		6600	113				
		7920	97				
SS1750-30-250	14	5390	109	330	980	70	2.2
		7700	97				
		9240	80				
SS1500-40-280	14	4620	145	375	980	70	2.0
		6600	129				
		7920	113				
SS1750-40-315	14	5390	145	420	980	70	2.2
		7700	129				
		9240	113				
SS2000-35-315	16	6160	129	420	980	72	2.4
		8800	113				
		10560	97				

# SS

## GENERAL ARRANGEMENT DRAWING

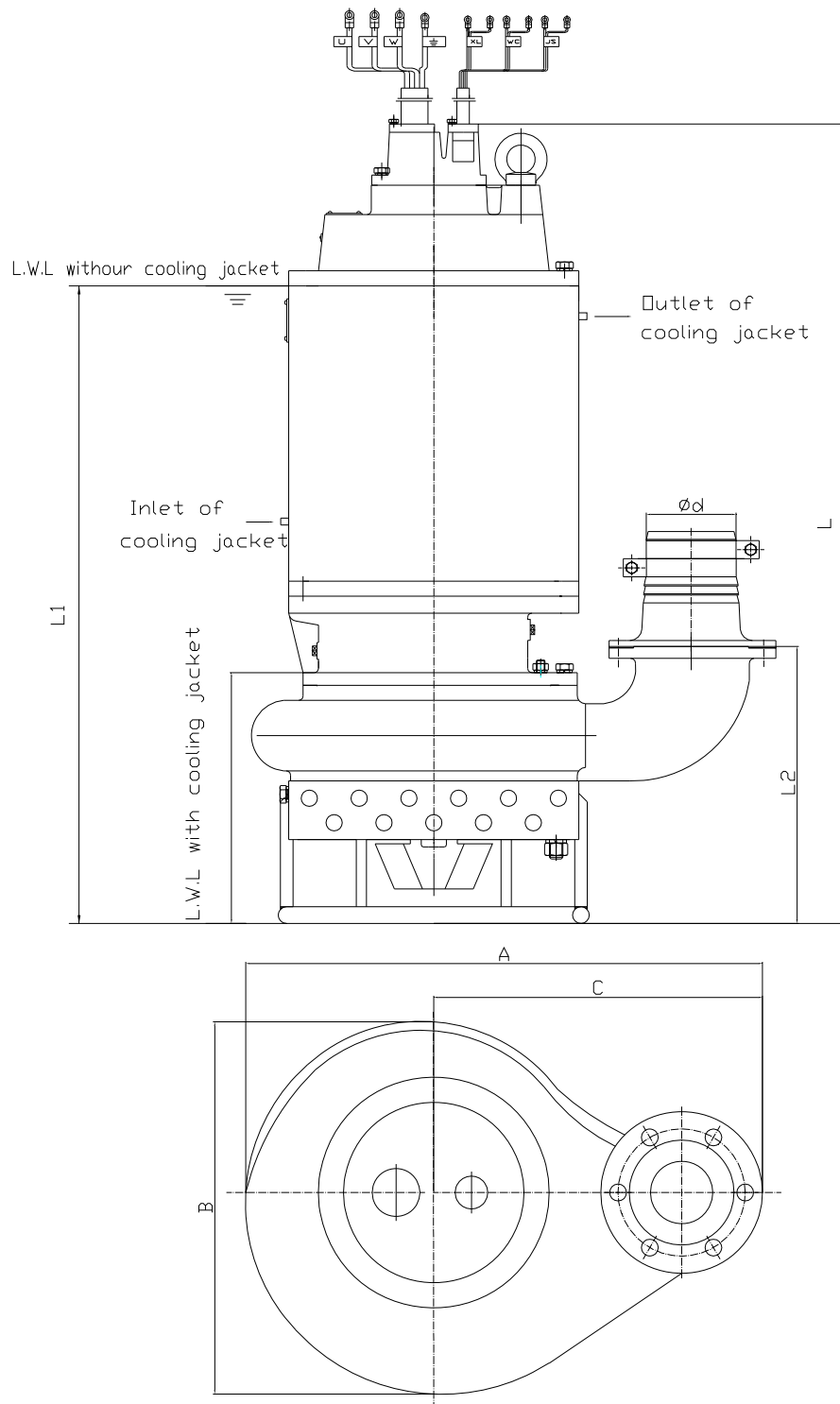

# SS DIMENSIONS

Model	Dimensions (inches)							Weight (pounds)
	L	L1	L2	A	B	C	d	
SS30-30-7.5	33.1	27.6	11.7	23.8	15.4	15.6	3.1	251
SS50-21-11	35.9	29.1	11.8	23.9	16.0	15.9	3.9	364
SS50-26-11	35.0	28.3	11.7	23.8	15.4	15.6	3.1	364
SS100-18-11	35.9	29.1	11.8	23.9	16.0	15.9	3.9	478
SS25-40-15	37.4	30.5	11.4	26.5	17.3	17.1	3.1	485
SS50-35-15	37.4	30.5	11.4	24.9	15.2	16.6	3.9	485
SS60-30-15	37.4	30.5	11.4	24.9	15.2	16.6	3.9	485
SS75-25-15	37.4	30.5	11.8	23.9	16.0	15.9	3.9	485
SS150-15-15	39.0	32.0	13.4	24.4	16.1	17.9	5.9	551
SS75-35-22	53.9	43.5	19.8	36.4	25.6	19.9	3.9	1279
SS75-45-22	53.9	43.5	19.8	36.4	25.6	19.9	3.9	1279
SS100-25-22	55.2	44.7	21.1	34.8	24.8	21.5	3.9	1279
SS150-22-22	55.2	44.7	21.1	34.8	24.8	22.4	5.9	1279
SS200-15-22	54.1	43.7	20.0	34.3	24.8	21.7	5.9	1279
SS100-35-30	57.2	45.0	16.7	32.8	24.8	23.8	3.9	1213
SS150-30-30	57.2	45.0	16.7	32.8	24.8	23.8	5.9	1213
SS200-25-30	57.5	45.2	18.5	32.9	24.8	23.8	5.9	1213
SS250-20-30	57.5	45.2	18.5	32.9	24.8	23.8	5.9	1213
SS100-45-37	61.4	46.1	19.1	37.4	25.6	25.2	3.9	1874
SS100-50-37	61.4	46.1	19.1	37.4	25.6	25.2	3.9	1874
SS300-20-37	61.7	46.1	20.1	42.1	23.4	30.5	5.9	1709
SS100-60-45	65.7	48.4	19.5	41.3	26.8	26.2	3.9	2205
SS200-30-45	66.9	49.4	19.5	39.6	26.2	25.6	5.9	2205
SS150-45-55	66.6	49.1	19.2	39.8	26.7	25.2	5.9	2514
SS250-35-55	66.9	49.4	19.5	39.6	26.2	25.6	5.9	2514
SS300-30-55	66.9	49.4	19.5	39.6	26.2	25.6	5.9	2514
SS600-15-55	67.7	50.2	20.3	41.4	28.0	26.6	9.8	2514
SS150-55-75	72.2	54.3	19.0	43.9	31.5	28.1	5.9	3396
SS150-60-75	72.2	54.3	19.0	43.9	31.5	28.1	5.9	3396
SS200-45-75	75.0	56.1	19.2	39.8	26.7	25.2	5.9	3396
SS200-55-75	72.2	54.3	19.0	43.9	31.5	28.1	5.9	3396
SS350-35-75	74.1	55.3	19.1	52.4	27.2	37.3	7.9	3396
SS400-25-75	74.3	55.5	19.1	56.0	26.2	41.2	7.9	3396
SS200-60-90	72.2	54.3	19.0	43.9	31.5	28.1	5.9	3418
SS200-55-90	72.2	54.3	19.0	43.9	31.5	28.1	5.9	3418
SS300-45-90	74.1	54.3	19.0	43.9	31.5	28.1	5.9	3418
SS300-50-90	75.7	55.9	19.3	60.6	33.4	43.7	5.9	3418
SS400-40-90	76.4	56.3	19.7	62.2	33.5	45.3	7.9	3418
SS500-25-90	74.3	55.5	19.1	56.0	26.2	41.2	7.9	3418
SS450-30-90	74.3	55.5	19.1	56.0	26.2	41.2	7.9	3418
SS250-60-110	86.7	60.1	19.1	43.9	31.5	28.1	5.9	4344
SS300-60-110	86.7	60.1	19.1	43.9	31.5	28.1	5.9	4344

# SS

## DIMENSIONS (CONTINUED)

Model	Dimensions (inch)							Weight (pounds)
	L	L1	L2	A	B	C	d	
SS400-50-110	87.6	61.0	19.7	46.9	29.9	31.1	7.9	4344
SS500-35-110	88.4	61.8	20.5	46.5	29.5	40.2	7.9	4344
SS600-30-110	88.4	61.8	20.5	46.5	29.5	40.2	9.8	4344
SS800-25-110	94.8	67.9	24.6	64.6	33.6	47.5	11.8	4344
SS1000-18-110	94.8	67.9	24.6	64.6	33.6	47.5	11.8	4344
SS780-26-110	94.8	67.9	24.6	64.6	33.6	47.5	11.8	4344
SS400-60-132	91.7	65.6	20.5	60.6	33.4	44.0	7.9	4410
SS500-45-132	91.3	65.2	18.6	44.3	32.4	29.1	7.9	4410
SS500-55-132	91.3	65.2	18.6	44.3	32.4	29.1	7.9	4410
SS800-35-132	99.9	70.2	23.7	62.2	31.6	46.3	11.8	4410
SS1000-22-132	97.0	70.9	24.6	64.6	33.6	47.5	11.8	4410
SS1250-15-132	99.9	70.2	23.7	62.2	31.6	46.3	11.8	4410
SS600-50-160	105.2	69.8	18.6	44.3	32.4	29.1	7.9	5843
SS650-52-160	105.2	69.8	18.6	44.3	32.4	29.1	7.9	5843
SS1250-25-160	113.8	78.3	26.5	63.0	32.3	46.5	13.8	5843
SS1000-30-160	113.8	84.1	23.7	62.2	31.6	46.3	11.8	5843
SS1750-15-185	114.2	84.3	25.7	65.4	32.3	49.6	13.8	7718
SS600-55-200	105.2	69.8	18.6	44.9	32.4	29.1	9.8	7497
SS800-45-200	115.5	78.5	28.0	66.4	35.4	48.4	11.8	7497
SS1000-40-200	115.5	78.5	28.0	66.4	35.4	48.4	11.8	7718
SS1500-20-200	120.5	80.7	26.5	69.7	34.3	72.8	13.8	7718
SS2000-20-200	120.5	80.7	26.5	74.0	34.3	74.6	15.7	7718
SS800-55-220	115.5	78.5	28.0	66.4	35.4	48.4	11.8	7497
SS1250-35-220	115.0	79.6	28.7	84.6	38.5	64.2	13.8	7497
SS1000-50-250	117.3	81.9	28.0	88.6	38.5	68.1	11.8	7718
SS1500-35-250	118.6	83.1	28.7	84.6	38.5	64.2	13.8	7718
SS1750-30-250	118.6	83.1	28.7	84.6	38.5	64.2	13.8	7718
SS1500-40-280	120.4	85.0	28.0	88.6	38.5	68.1	13.8	7938
SS1750-40-315	127.4	89.0	31.7	85.8	40.4	65.0	13.8	8159
SS2000-35-315	127.4	89.0	31.7	89.0	40.4	68.1	15.7	8159

# SECTIONAL DRAWING

## MATERIALS OF CONSTRUCTION

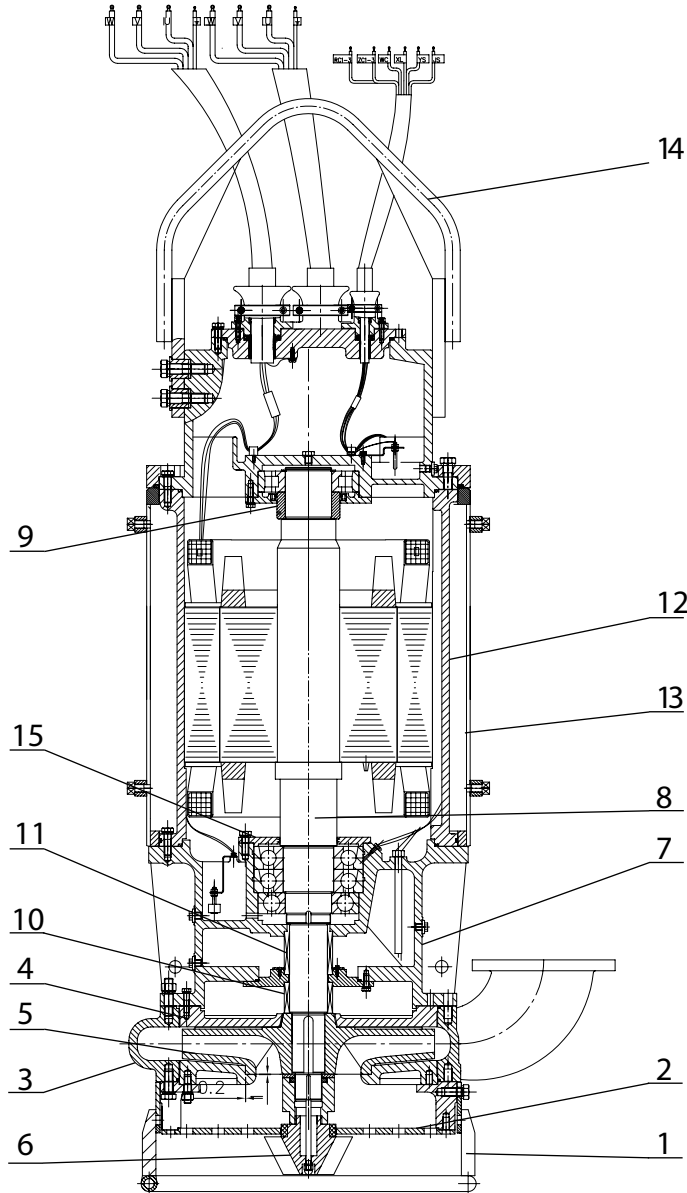

No.	Description	Standard Material	Material Options
1	Support Frame	Mild Steel	
2	Strainer	420 Stainless Steel	
3	Pump Casing	27% Chrome White Iron	316 Stainless Steel / Duplex <sup>1</sup>
4	Back Plate	27% Chrome White Iron	316 Stainless Steel / Duplex <sup>1</sup>
5	Impeller	27% Chrome White Iron	316 Stainless Steel / Duplex <sup>1</sup>
6	Agitator	27% Chrome White Iron	316 Stainless Steel / Duplex <sup>1</sup>
7	Oil Chamber Housing	Cast Iron	
8	Shaft	420 Stainless Steel	
9	Shaft Sleeve	420 Stainless Steel	
10	Wet End Mechanical Seal	304 Stainless Steel	
11	Motor Mechanical Seal	304 Stainless Steel	
12	Motor Casing	Cast Iron	
13	Motor Cooling Jacket	Fabricated Mild Steel	
14	Lifting Brace	Mild Steel	
15	Bearing Covers	Cast Iron	
16	Oil Chamber Cover	Cast Iron	



# AF FORTH PUMPS

---



### AF design features

**Bearing assembly-** Bearing assembly of AF series is the same with that of SV, SVR series. Bearing housing is installed with motor frame base or supporting plate, i.e. pump and motor are connected either directly with coupling or through pulley and belt. Pulleys can be exchanged conveniently to adjust the pump rotating speed to satisfy the varying operating condition.

**Feeding tank-** Feeding tank can be steel, stainless steel or coated with rubber with overflow box and tangential inlet. The former can transmit the excessive incoming slurry back to its pit, while the latter will allow the slurry quickly get into the pump body and make part of the foams disappear.

**Double casings structure the pump head.** Wetted parts are metal lined, rubber lined or of other non-metallic material according to the different slurries.

### AF product feature

AF series froth pumps are MST newly designed & developed products based on the advanced technology from home and abroad. Being popularized and promoted;

now they are widely used in the metallurgical industrial, mining sector, coal ore and chemical engineering to handle abrasive and corrosive slurries with froth. When operated, AF pumps can effectively eliminate foam and froth in slurry and will also function properly even with inadequate feeding slurry, thus making them the ideal choice for delivering foam slurries, esp, in flotation process.

### Type notation

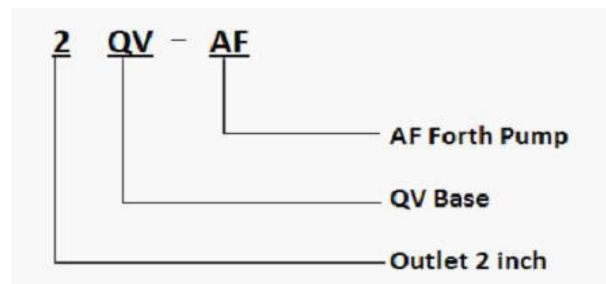

## froth pumps

Construction drawing of froth pump

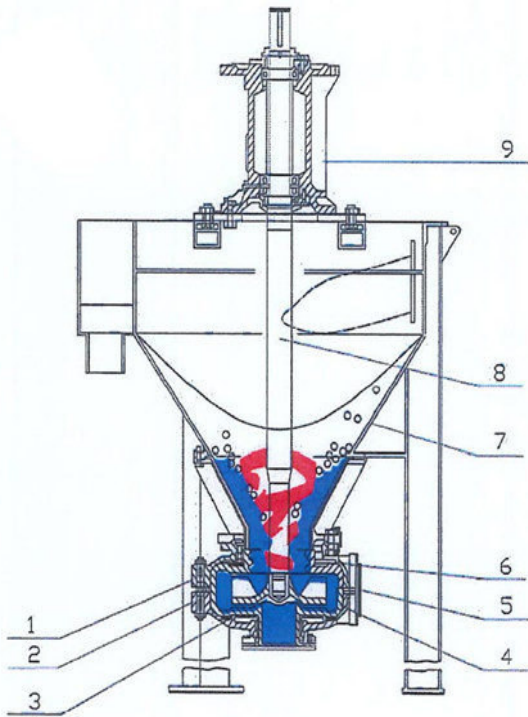

1. Frame plate
2. Cover plate
3. Cover plate liner insert
4. Volute
5. Impeller
6. Frame plate liner
7. Tank
8. Shaft
9. Bearing housing

Froth pumps section chart

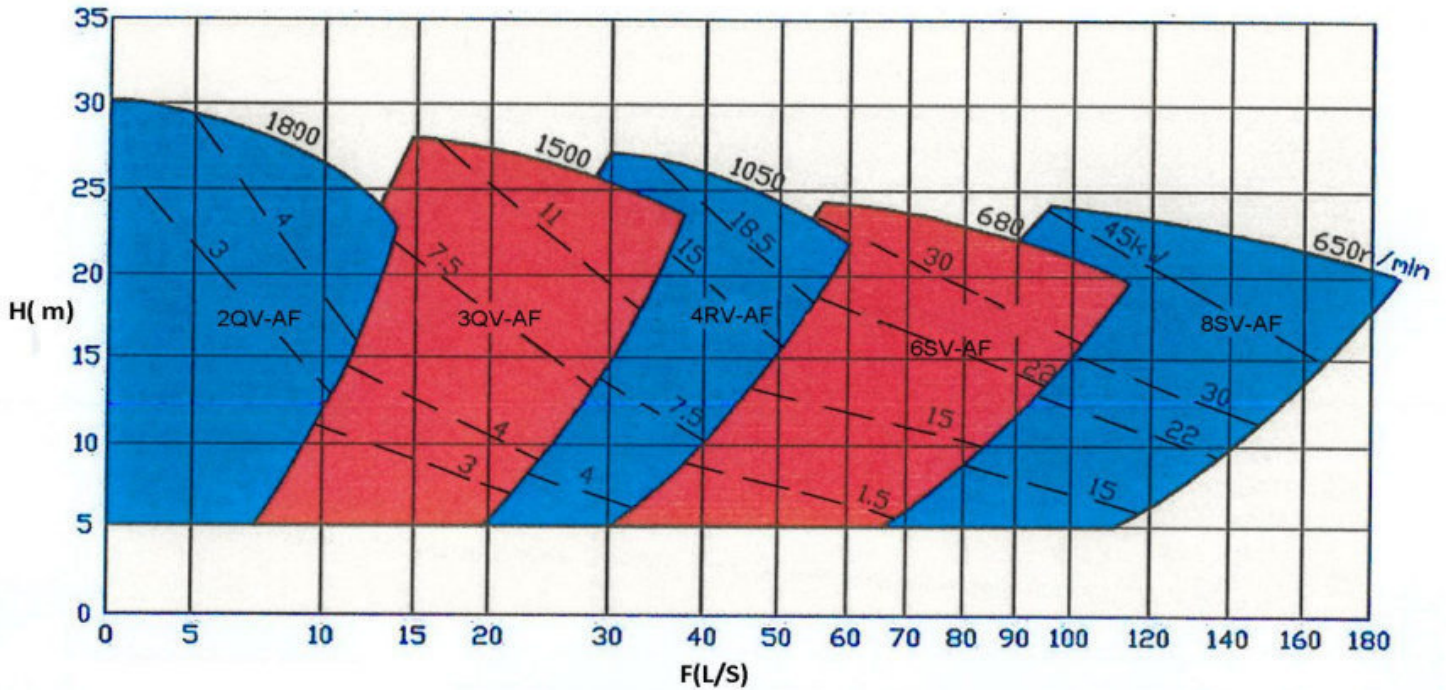

Note: Approximate performance for clear is used for primary selection only

### Technical parameters for select pumps

Modal	Capacity (m <sup>3</sup> /h)	Head (m)	Speed (r/m)	Eff (%)	Installed with power	Diameter	
						Inlet (mm)	Outlet (mm)
AF/50QV	7.6-42.8	6-29.5	800-1800	45	15	100	50
AF/75QV	23-77.4	5-28	700-1500	55	18.5	150	75
AF/100RV	33-187.2	5-28	500-1050	55	37	150	100
AF/150SV	80-393	5-25	250-680-	55	75	200	150
AF/200SV	126-575	5.5-25.5	350-650	55	110	250	200

### Forth Pump Outline Dimension Drawing

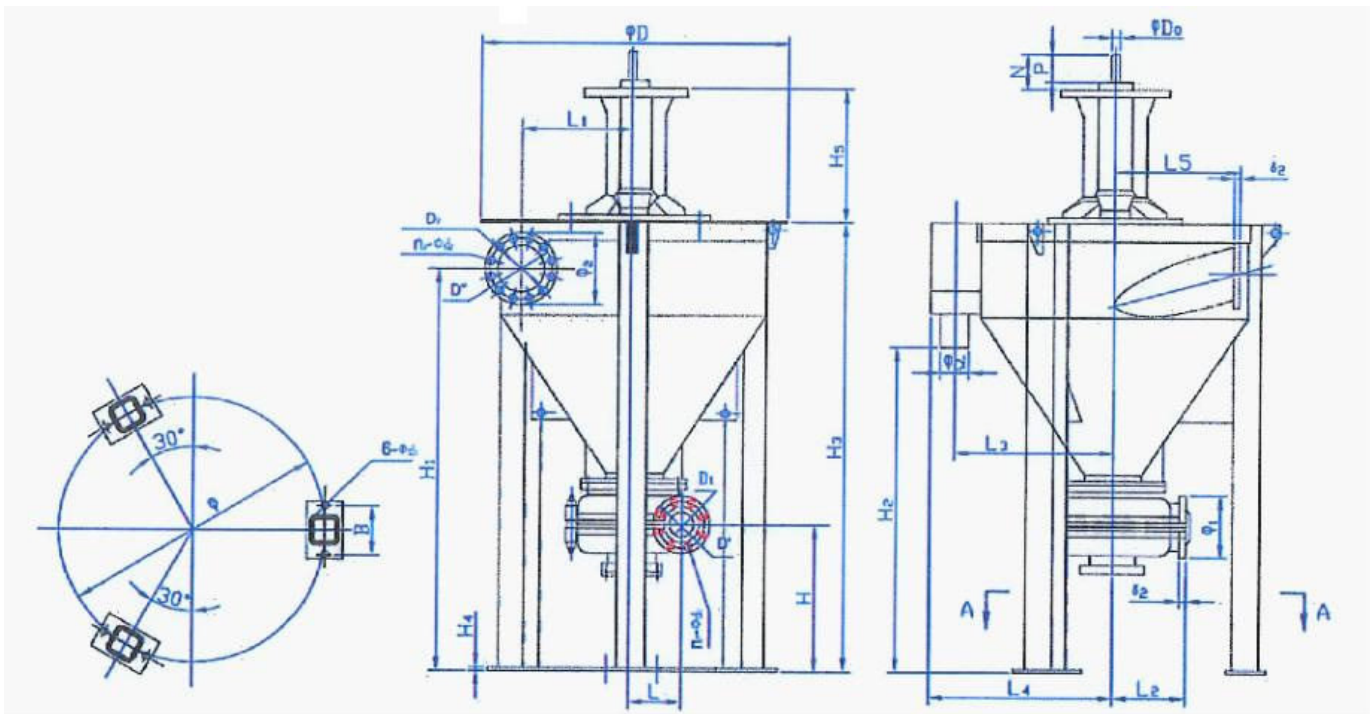

Modal	Dimension																			Discharge						Intake flange						
	H	H <sub>1</sub>	H <sub>2</sub>	H <sub>3</sub>	H <sub>4</sub>	H <sub>5</sub>	L	L <sub>1</sub>	L <sub>2</sub>	L <sub>3</sub>	L <sub>4</sub>	L <sub>5</sub>	φ	B	φD	N	P	φd	φd <sub>3</sub>	φD <sub>0</sub>	D <sub>1</sub>	D <sub>1</sub> '	φ <sub>1</sub>	n <sub>1</sub>	φd <sub>1</sub>	δ <sub>1</sub>	D <sub>2</sub>	D <sub>2</sub> '	φ <sub>2</sub>	n <sub>2</sub>	φd <sub>2</sub>	δ <sub>2</sub>
2QV-AF	382	1140	850	850	12	474	138	360	210	480	565	380	800	140	938	174	110	100	19	40	51	146	184	4	19	25	102	178	216	4	19	12
3QV-AF	467	1250	950	1400	12	474	149	354	262	510	625	445	840	140	938	174	110	168	18	40	76	191	229	4	22	27	152	235	279	8	18	16
4RV-AF	506	1720	1310	1810	160	637	229	537	338	740	860	600	1230	230	1444	238	170	150	19	65	102	235	279	4	22	32	203	292	337	8	19	12
6SV-AF	791	2430	1950	2770	20	875	318	696	460	1020	1180	800	1700	300	1970	300	210	219	22	80	152	324	365	8	21	38	305	406	157	12	22	20
8SV-AF							381		470												203	375	432		29	44						





**DEPUMP TECHNOLOGY SHIJIAZHUANG CO.,LTD**

Email: [sales@deonpump.com](mailto:sales@deonpump.com) /[serena@deonpump.com](mailto:serena@deonpump.com)

Web: <http://deonpump.en.alibaba.com/>

Add: NO 19 of Pingan North Street, Shijiazhuang, Hebei, China

Tel: +86-312-6795175 Fax: +86-312-3085383